

METAL HYDRIDE TECHNOLOGIES FOR POWER ENGINEERING

V. I. Borzenko, D. O. Dunikov, S. P. Malyshenko



Laboratory for Hydrogen Energy Technologies
Joint Institute for High Temperatures
Russian Academy of Sciences
(IVTAN H2lab)
h2lab@mail.ru

Hydrogen technologies for power production

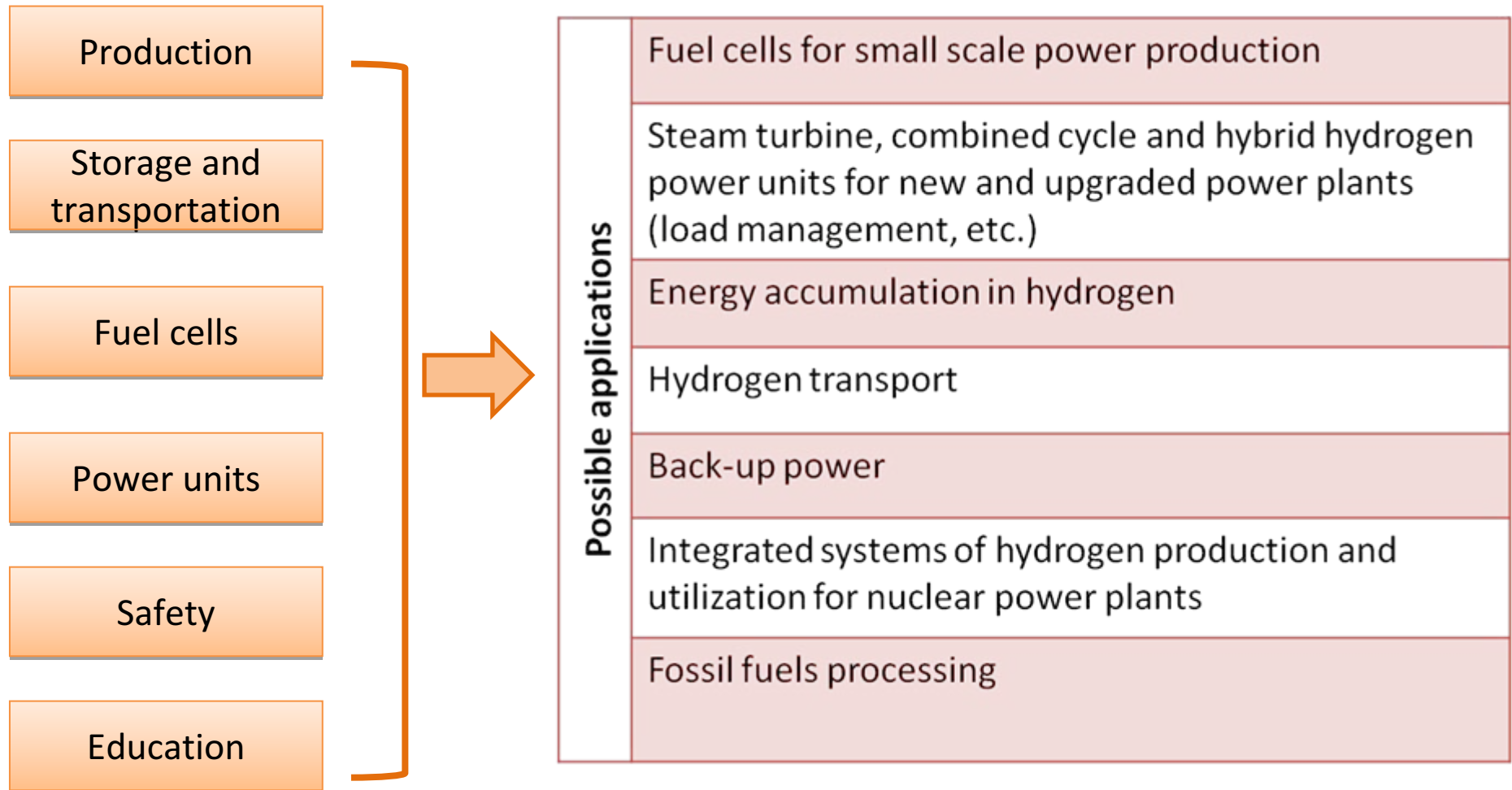

Objective:

Increasing of energy efficiency and environmental safety of power production and utilization of primary energy sources by implementation of reversible solid-state hydrogen storage and purification technologies

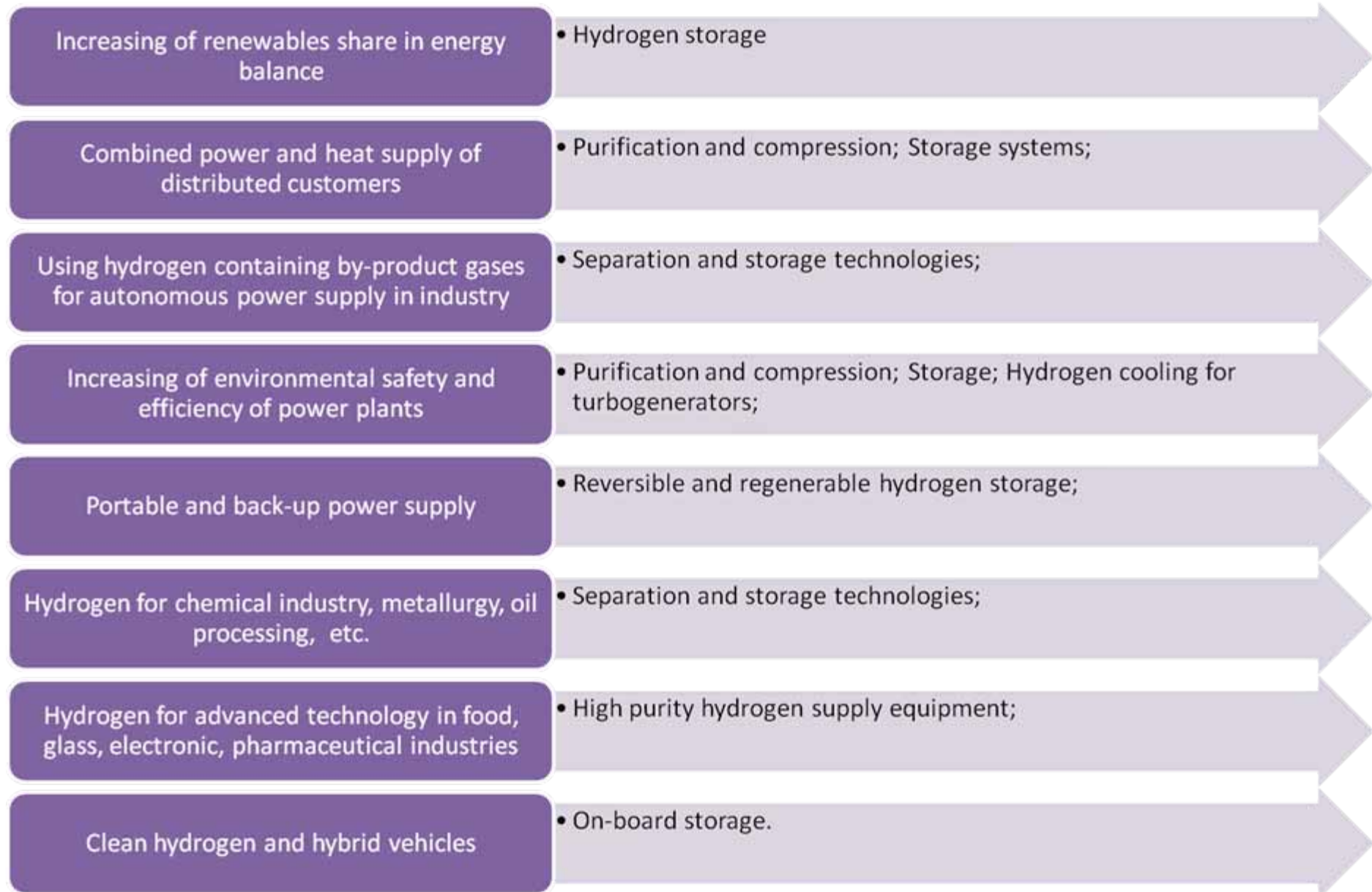

Low temperature metal hydride systems

Advantages:

Near ambient operating temperatures and pressures

(higher safety, ease of operation)

Highly flexible

(properties of storage materials can be optimized for specific applications)

Compact

(high volumetric density)

Safe

(hydrogen is stored in solid state)

Selective sorption of hydrogen

(can be used for purification)

Efficient

(waste heat utilization, renewable energy, low investment, etc.)

Main disadvantage: Low gravimetric hydrogen density (< 2% wt.)

(Can be used in stationary applications, niche market)

Selective hydrogen sorption: possible applications

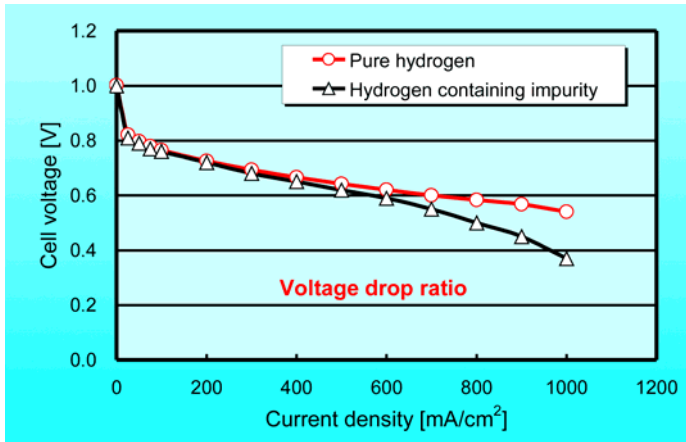

(Japan Automobile Research Institute)

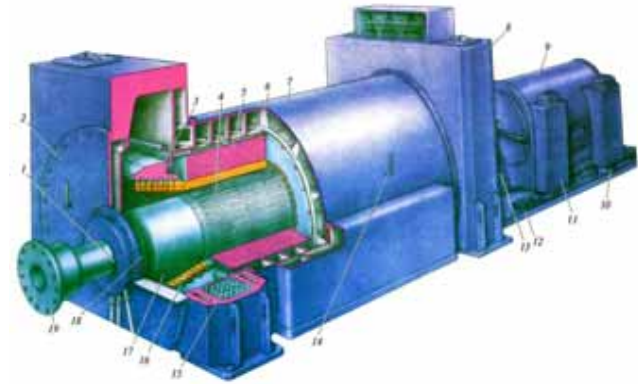

Windage losses are 30-40% of overall losses in hydrogen cooled turbogenerators

PEM Fuel Cells require pure hydrogen

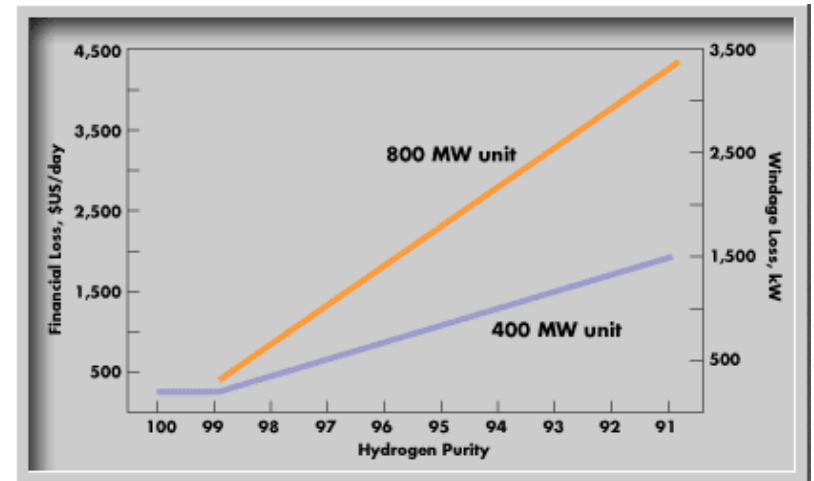
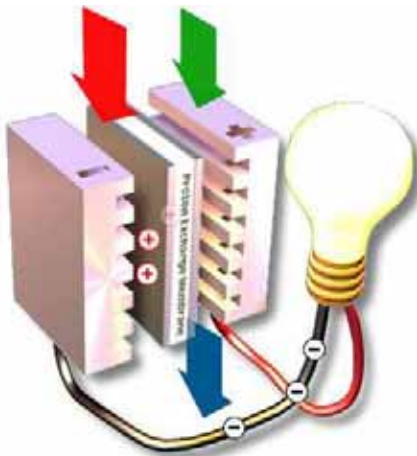

Environment One Corporation

Possible near term markets

Fuel cell power supply (PEM preferably) for autonomous, uninterruptible and emergency power supply (emergency response, backcountry, data centers, clinics, special applications)

Special transport applications (mine trains, fork lifts, airport vehicles, locomotives, ships, etc.)

Power systems (preferably renewable) with high environmental requirements (national parks, resorts, etc.)

Hydrogen cooled turbine generators

On-site hydrogen storage and purification for technological, educational and research purposes

Main barriers: thermal management

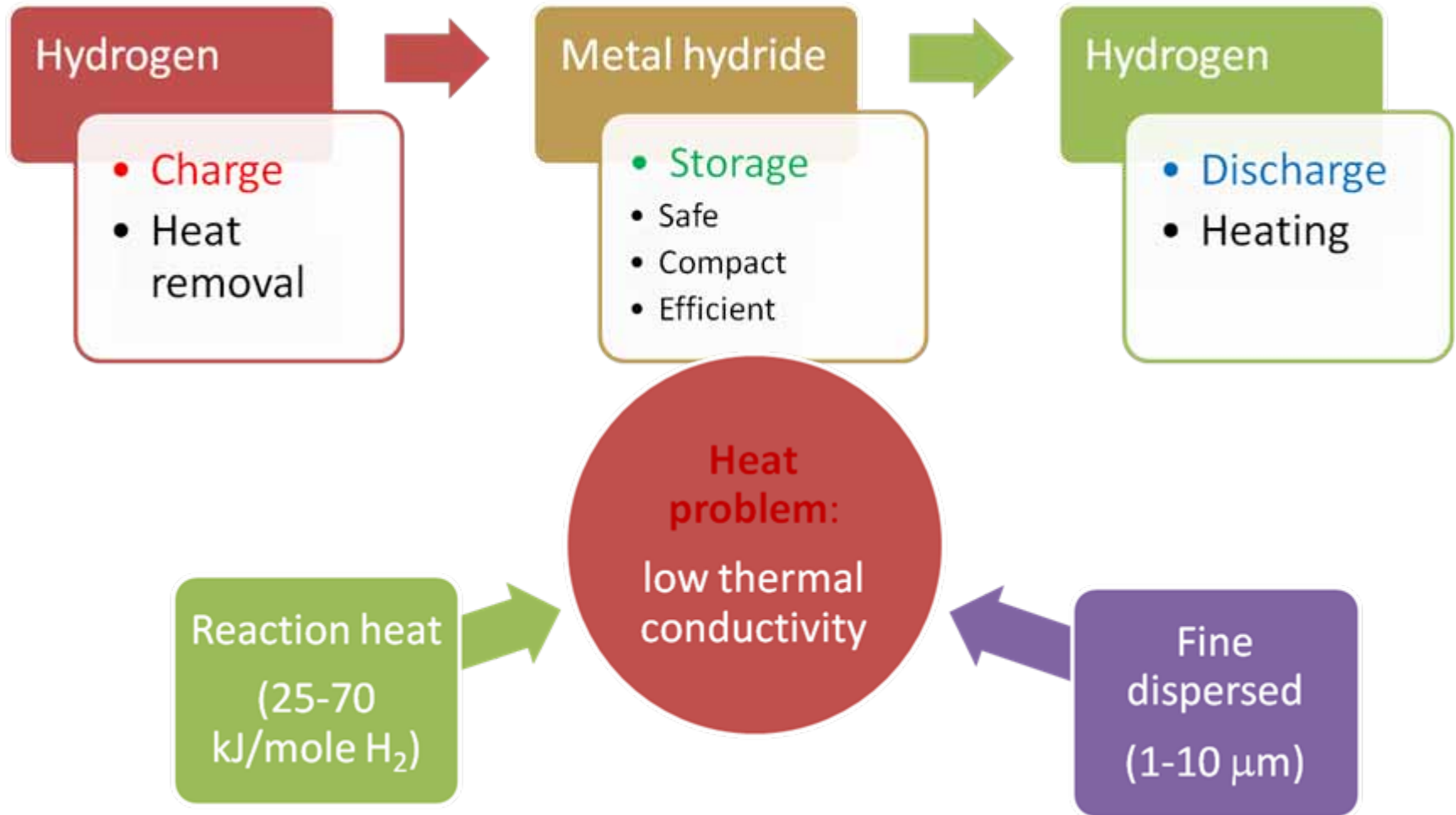

Thermal problem

Low thermal conductivity of metal hydride beds is the cause for overheating and stop of the sorption reaction.

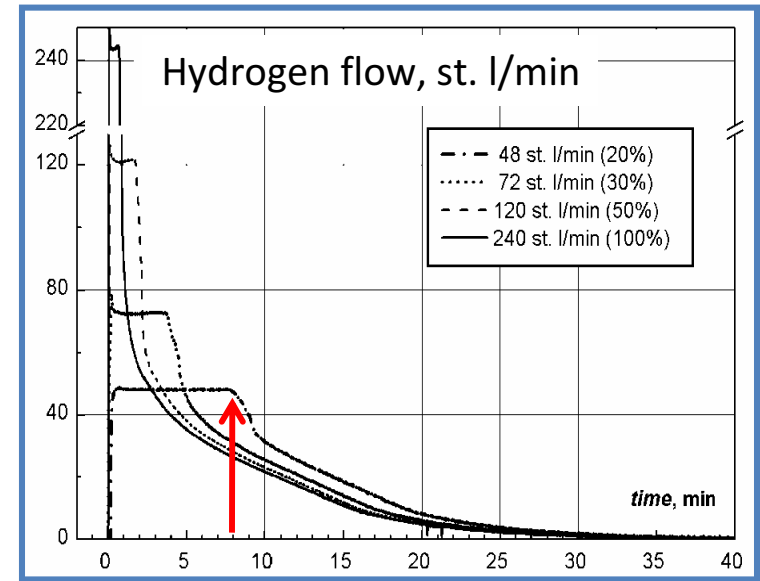
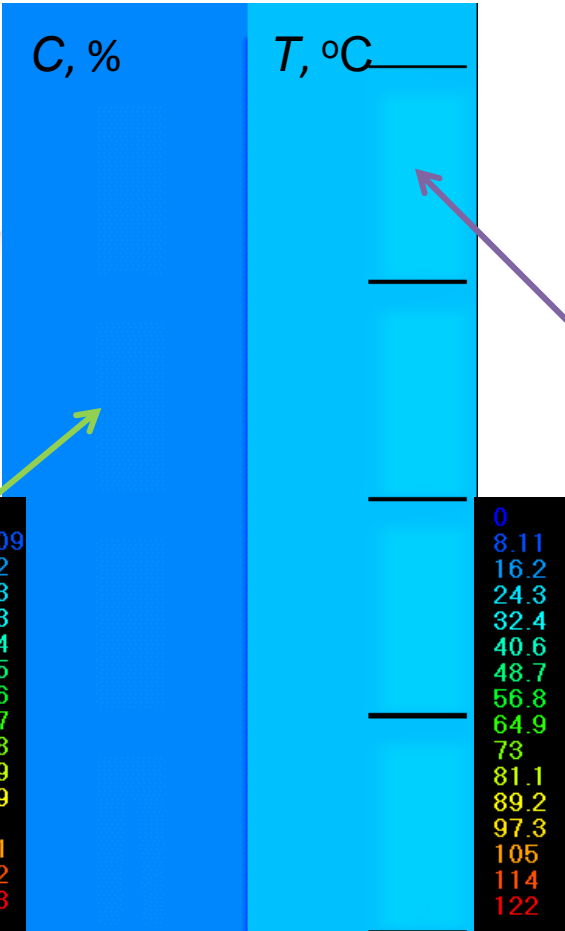
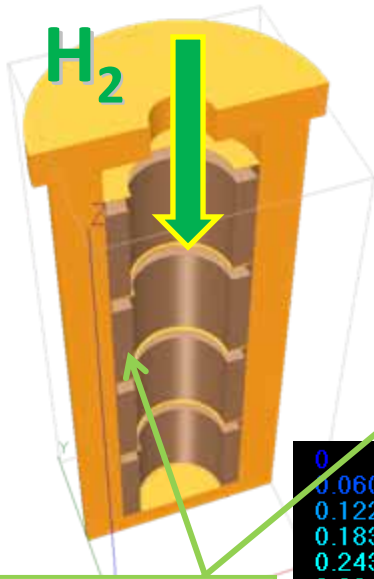

Experiments prove that the charging regime is broken at reaching the temperature maximum in MeH medium

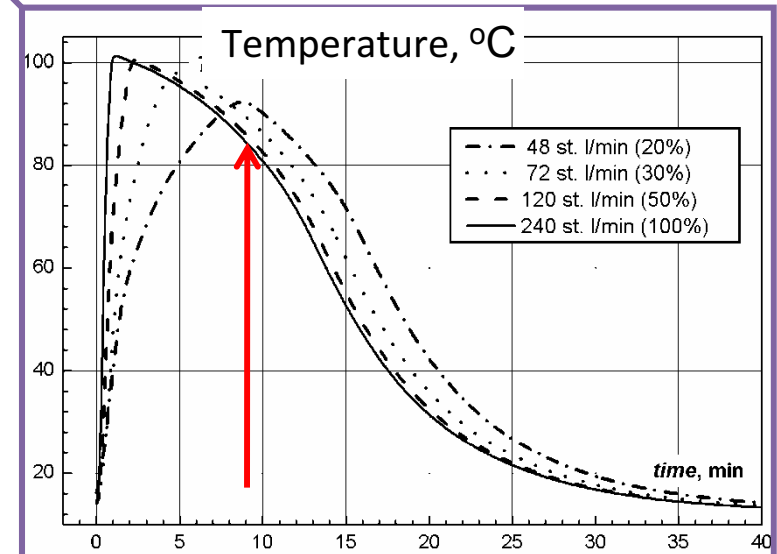

Hydrogen mass content C and temperature fields T calculation in reactor.

Main barriers: impurities

Some substances are poisoning the surface of particles in metal hydride bed – preliminary purification is needed

Neutral impurities (CO_2 , N_2 , etc.) rapidly filling the free volume of reactor blocking the sorption – admixtures must be removed from the reactor

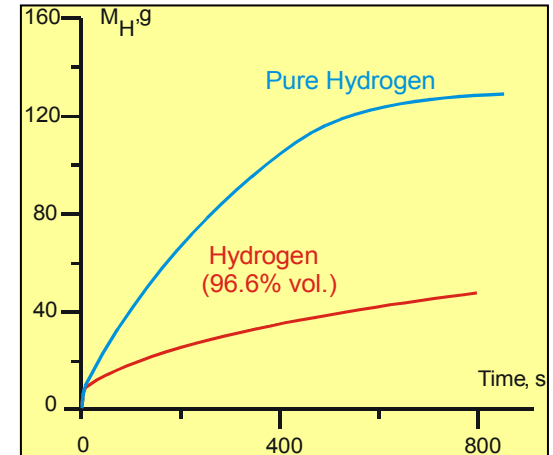

Impurity	Type of impurity	Number of cycles for 2 times capacity drop (at 0,1% vol.)
Ar, He, N_2 , CH_4 , C_2H_6 ,...	“Inert”	>1000
CO_2 , (NH_3) ,...	Chemosorption	~1000
C_2H_4 , C_2H_2 , (C_3H_6) ,...	Catalytic interaction	~1000
O_2 , H_2O ,...	Chemical reaction	~100
CO , SO_2 , H_2S , (CH_3SH) ,...	“Poisoning”	1-2

Source: B.P. Tarasov (IPCP)

IVTAN H2lab

main activities in the field of hydrogen storage

Metal hydride technologies		<i>In cooperation with</i>
	Experimental investigations of heat and mass transfer in MH devices	
	Mathematical modeling of processes in MH devices	MPEI
	New materials	MSU, IPCP RAS, SAIAMC (South Africa), University of Geneva (Switzerland)
	Reactor design and testing	
	System integration	GUAP

Experimental investigations: modular reactor

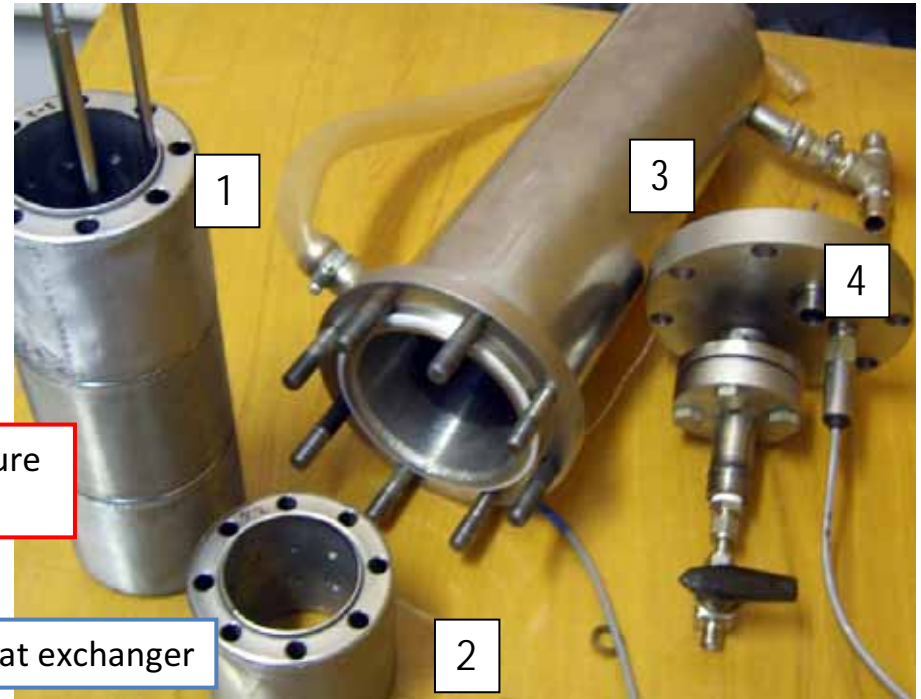
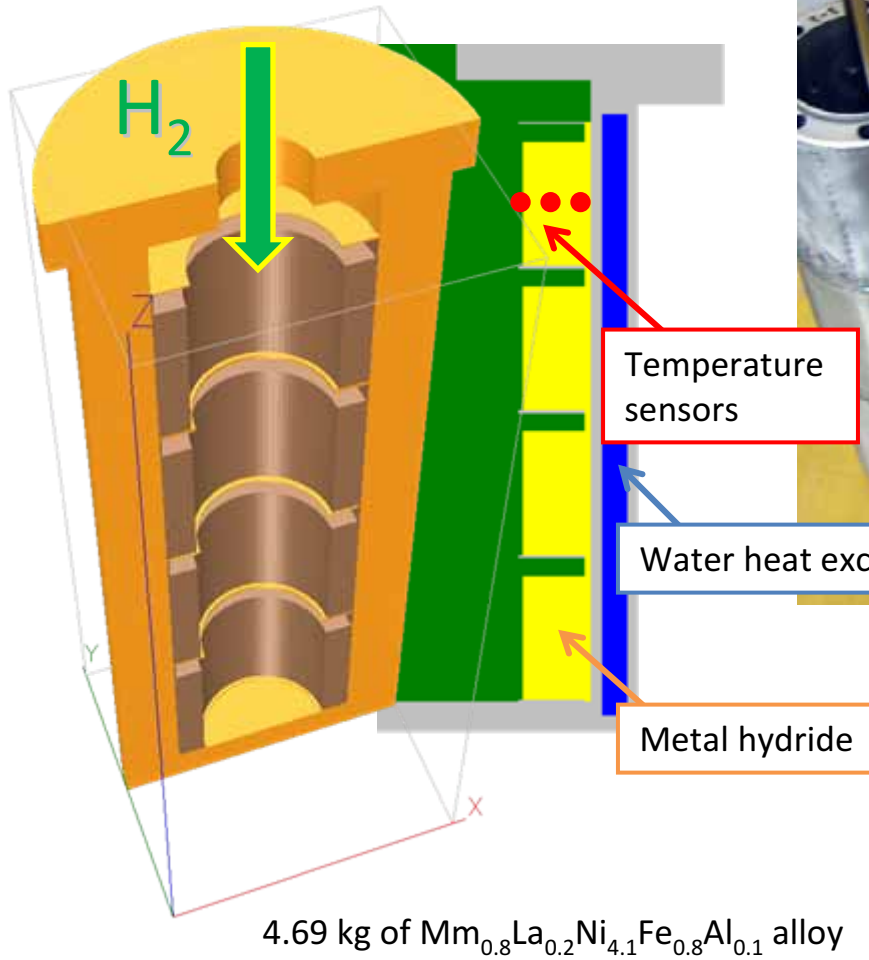

1 – hydride cartridge; 2 – MH module; 3 – casing with water heat exchanger; 4 – cover.

$$\frac{V_g}{V_{MeH}} \geq \frac{\Delta C \cdot x}{(1-x) \cdot \rho_{H_2}(p, T)} \gamma_{MeH} \cdot (1 - \varepsilon) - \varepsilon$$

Effective thermal conductivity

Regular heating rate method

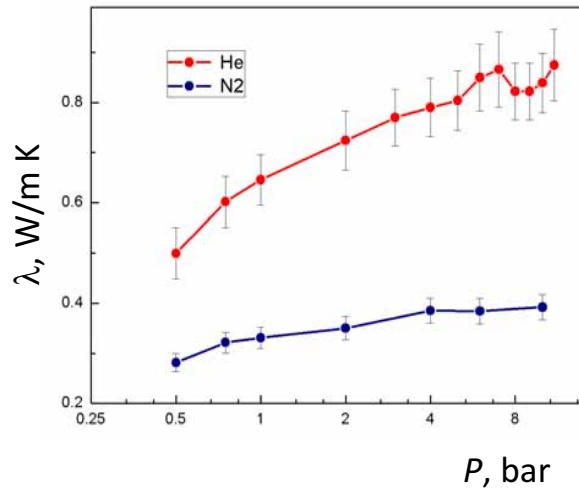
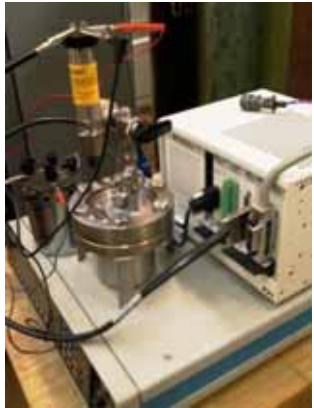

Due to very small size of pores ETC of beds depends strongly on hydrogen pressure. To calculate ETC is needful to take into account structure of metal hydride bed and pore size distribution $f(x)$:

$$\langle \lambda_g \rangle = \int_0^{\infty} \lambda_g(x) f(x) dx$$

Co-axial cylinder method

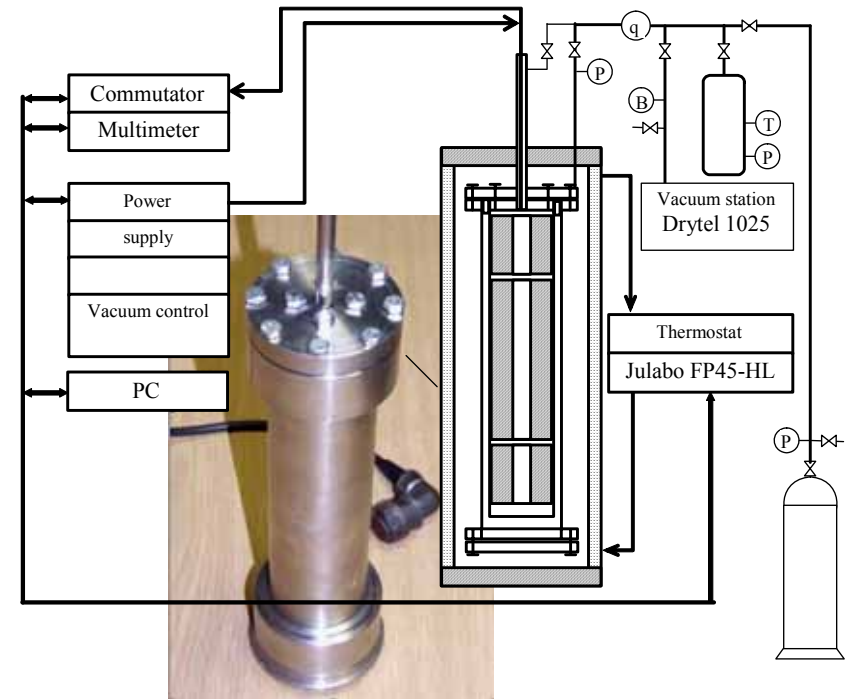

Mathematical model: 3D multispeed continuum model for heterogeneous medium

Mathematical formulation includes a set of 3D Navier-Stokes unsteady equations of mass and energy conservation for solid and gas and momentum equation for gas.

Assumptions:

- Gaseous phase is homogeneous mixture of N components, one of which is hydrogen;
- Solid phase includes impermeable structures (unit walls), permeable “passive” structures (internal tube with porous wall), permeable “active” structures (layers of intermetallic particles);
- The gaseous phase is ideal from the thermodynamic viewpoint;
- Specific isobaric heat capacity of gas mixture components is constant;
- The viscous dissipation and compression work are negligible.

Closing equations: interface interaction, absorption/desorption kinetics, effective permeability and coefficient of effective thermal conductivity

Mathematical modeling: temperature in reactor

Sorption: $p = 8 \text{ bar}$, $T_{cool} = 20 \text{ }^\circ\text{C}$, $\alpha_{cool} = 2000 \text{ W}/(\text{m}^2\text{K})$

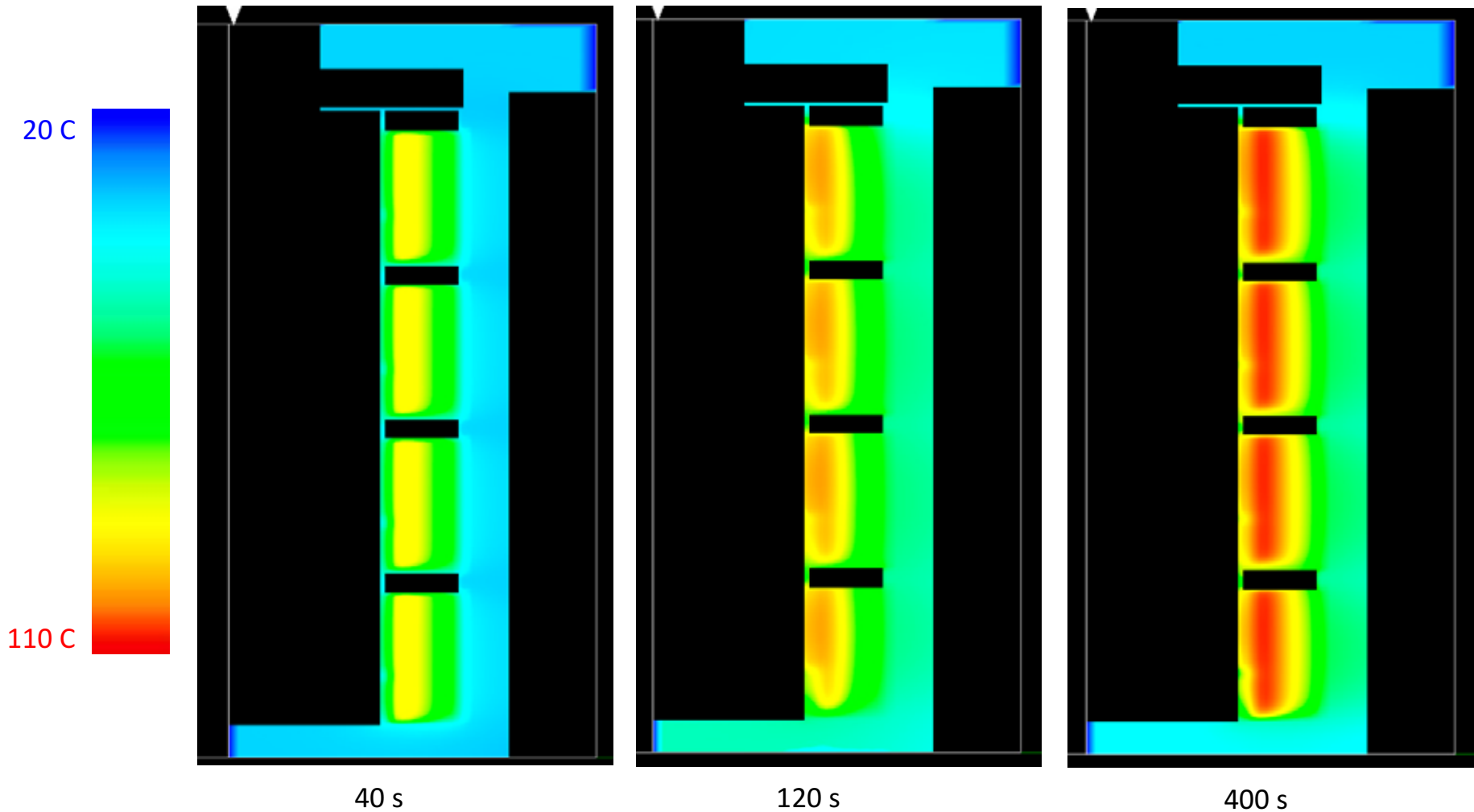

Mathematical modeling: hydrogen concentration

Sorption: $p = 8 \text{ bar}$, $T_{cool} = 20 \text{ }^\circ\text{C}$, $\alpha_{cool} = 2000 \text{ W}/(\text{m}^2\text{K})$

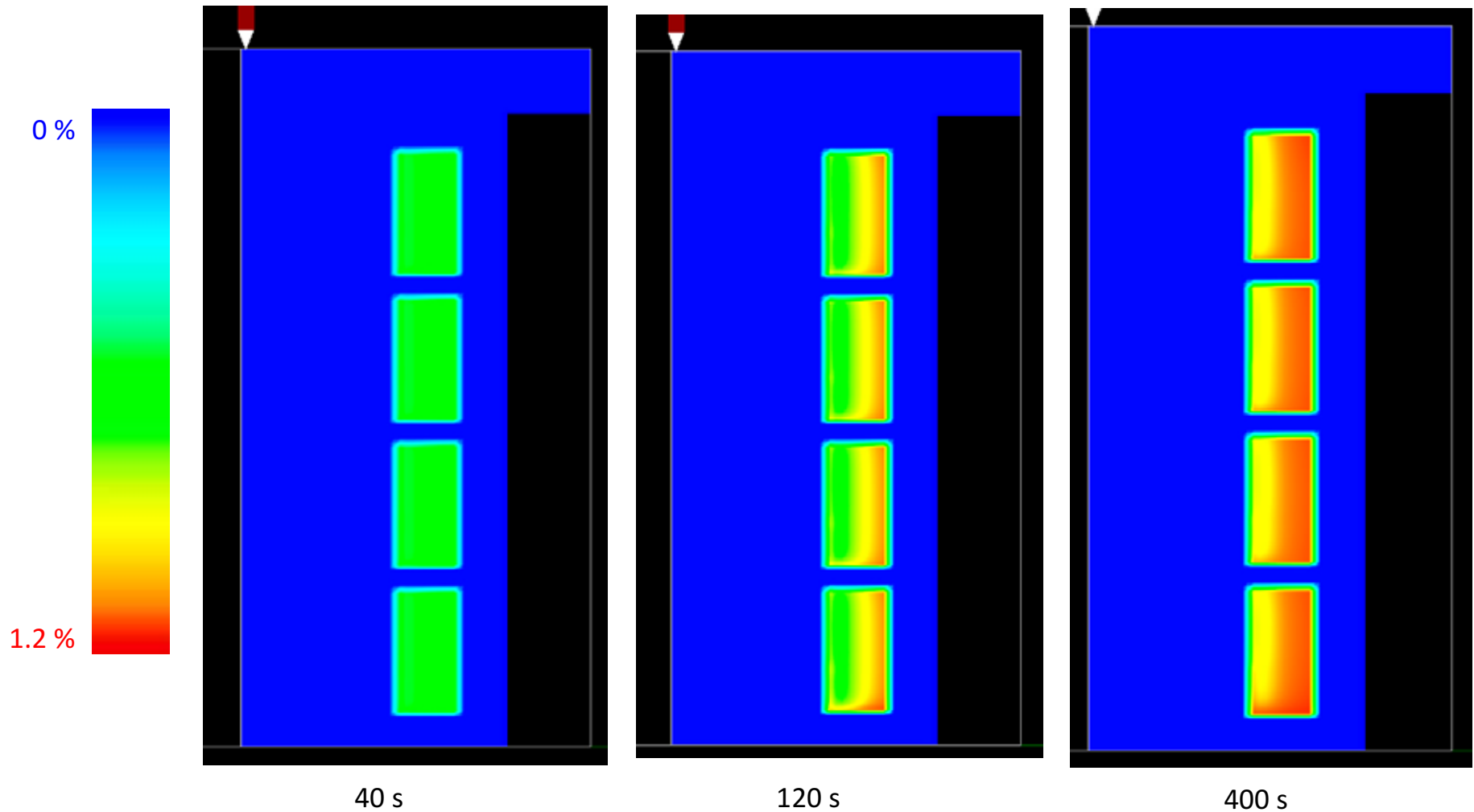

H2Lab IVTAN Experimental Facility for Complex Investigations of Solid-state Reversible Hydrogen Storage and Purification Systems

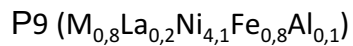
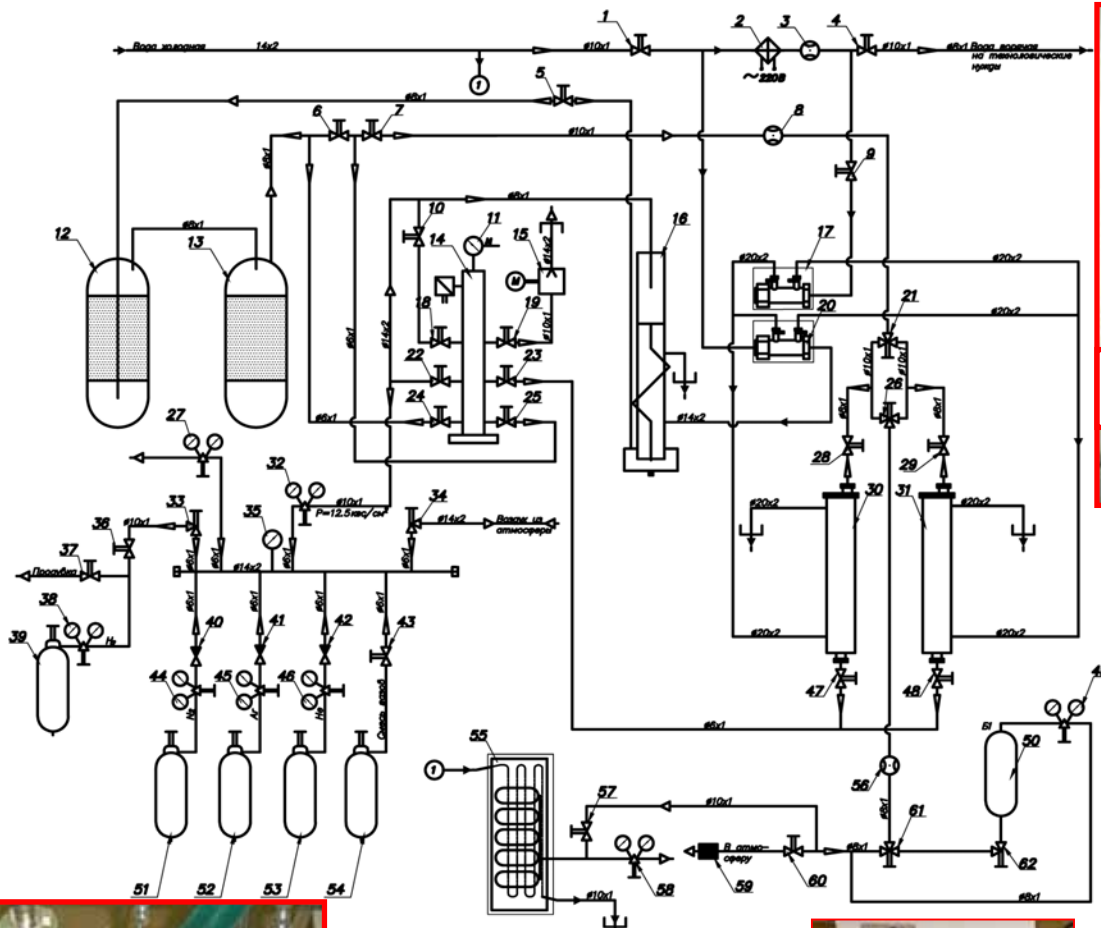

Metal Hydride reactors Type 1



Purification system



GenCore Fuel Cell



Control system



Storage unit

Experimental investigations: charge and discharge

Water flow rate, kg/s	0.06	0.03
Sorption 30 min		
Cold water, °C	19	19
Result, st.l	754	760
Desorption 30 min		
Hot water, °C	90	97
Result, st.l	600	617
<i>Hydrogen flow was set at 120 st.l/min</i>		

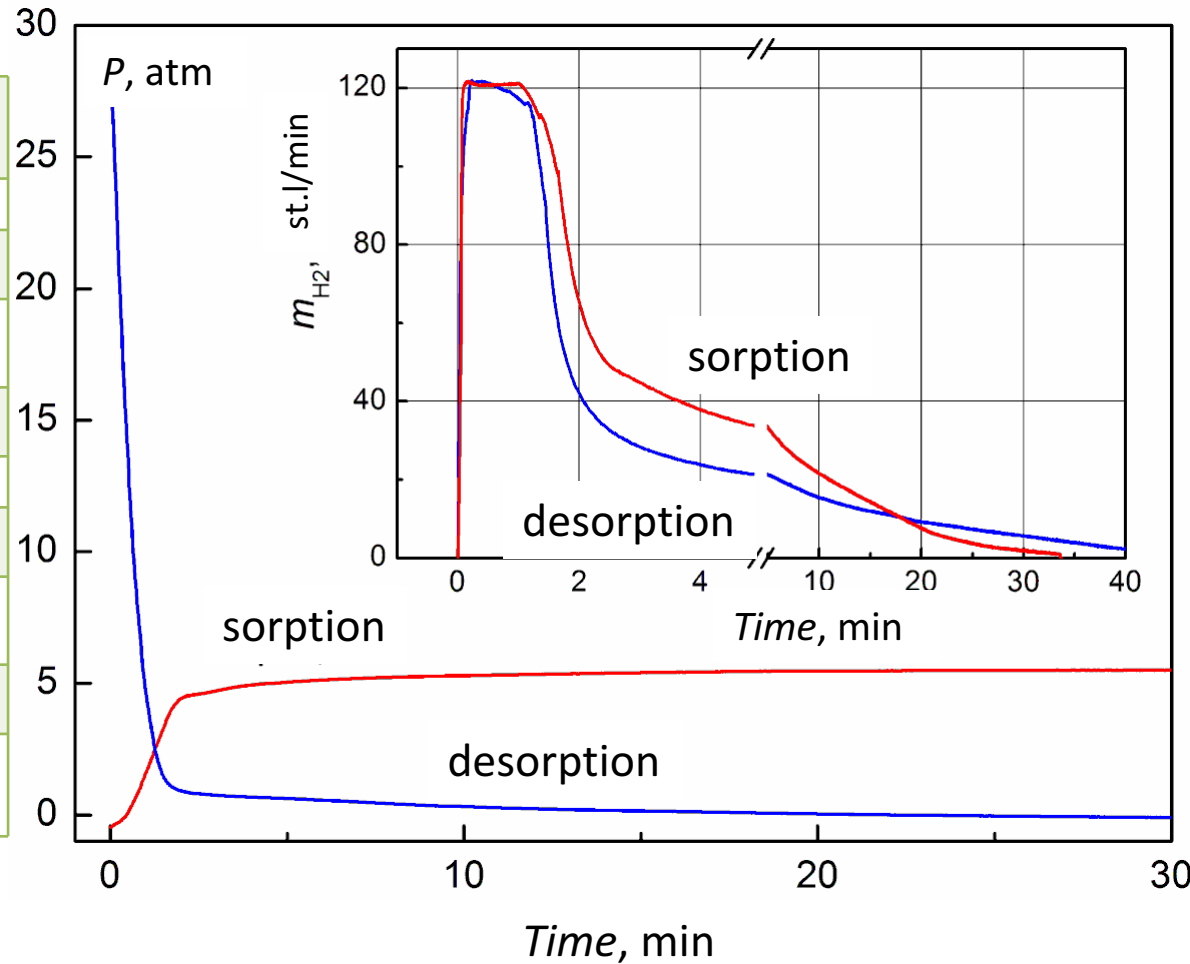

Comparison of calculation and test results

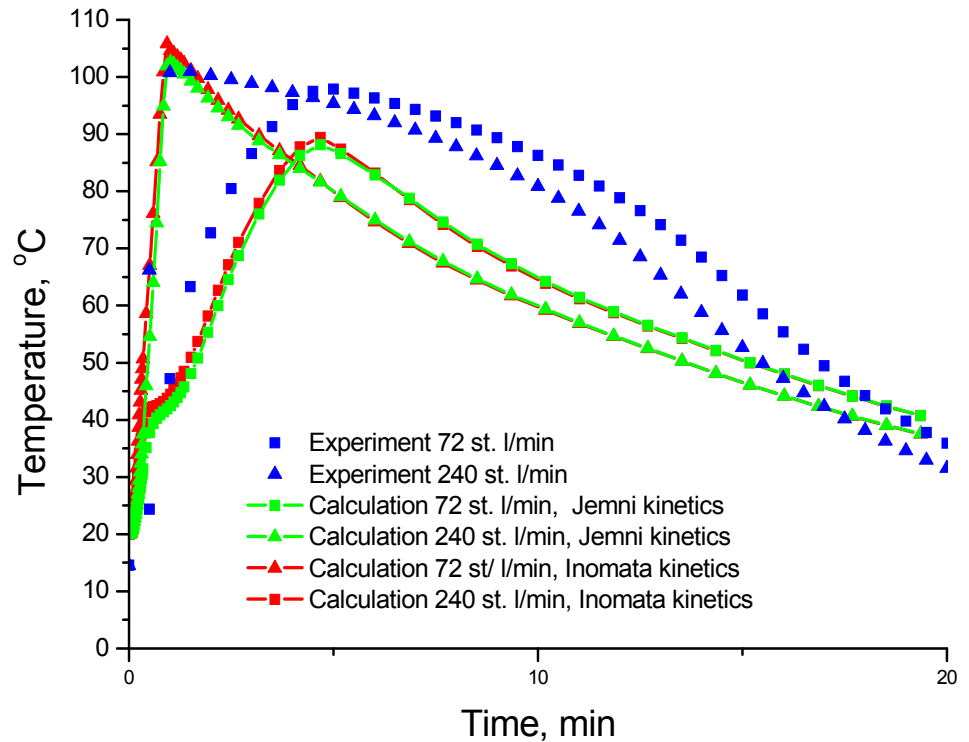
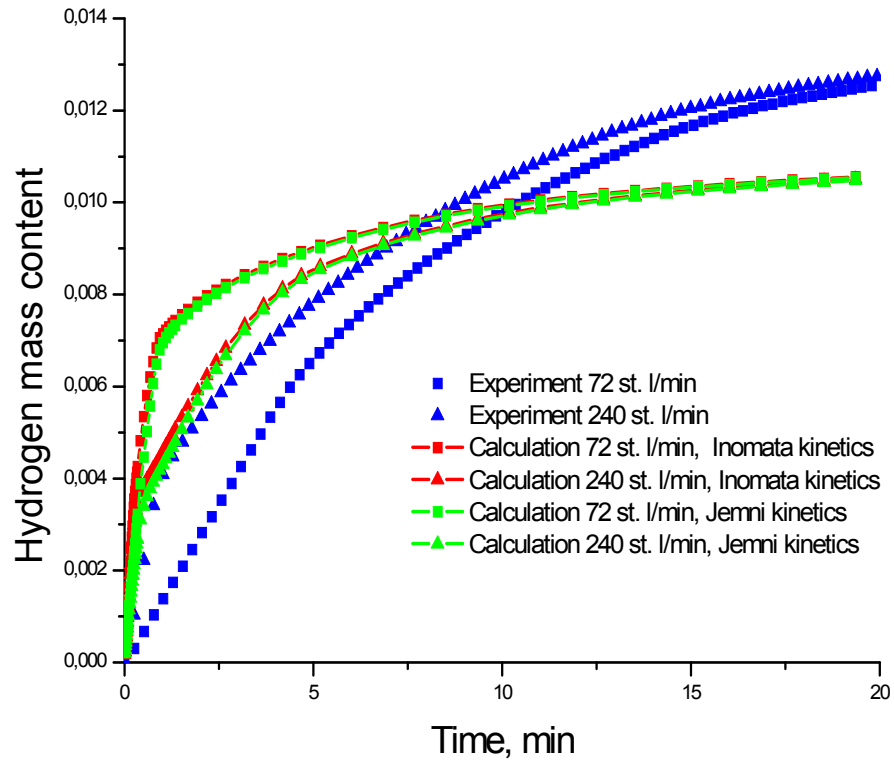

Comparison of calculation and test results

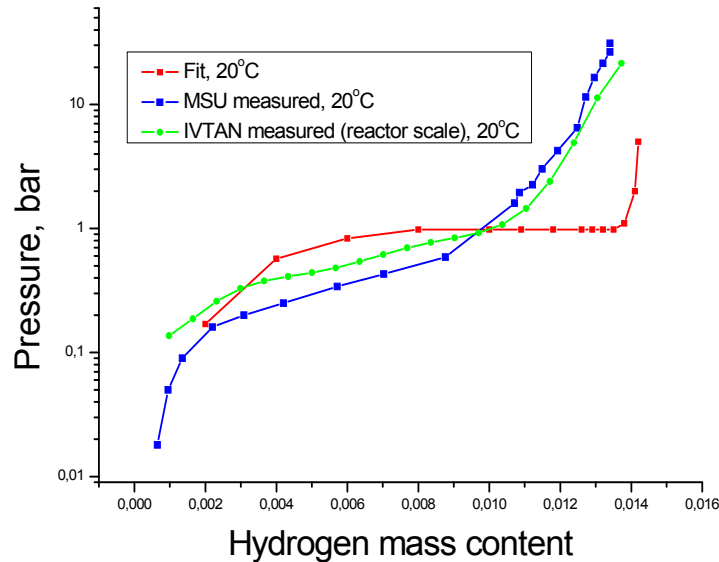

The problem of calculations and measurements correspondence can be solved by reliable PCT measurement and also by taking into account the scaling effect at transition from lab- scale to reactor-scale amounts of hydrogen absorbing materials

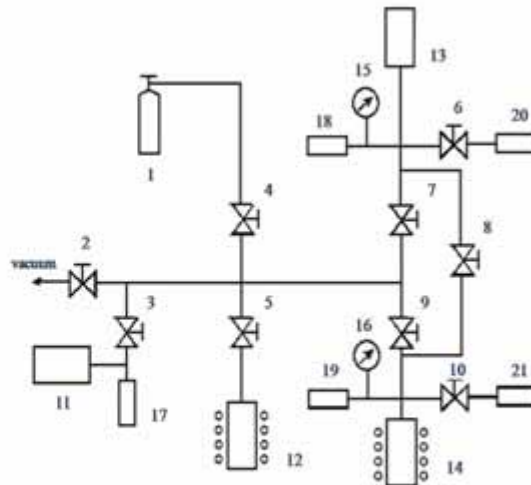

Facility for hydrogen desorption isotherms measurement. 1 - vessel with hydrogen; 2-10 - valves; 11, 13, 14 - autoclaves; 12 - hydrogen accumulator with LaNi_5 ; 17 - pressure sensor (0-1 atm); 18, 19 - pressure sensors (0-150 atm); 20, 21 - pressure sensors (0-10 atm)

Reactor design optimization: modeling

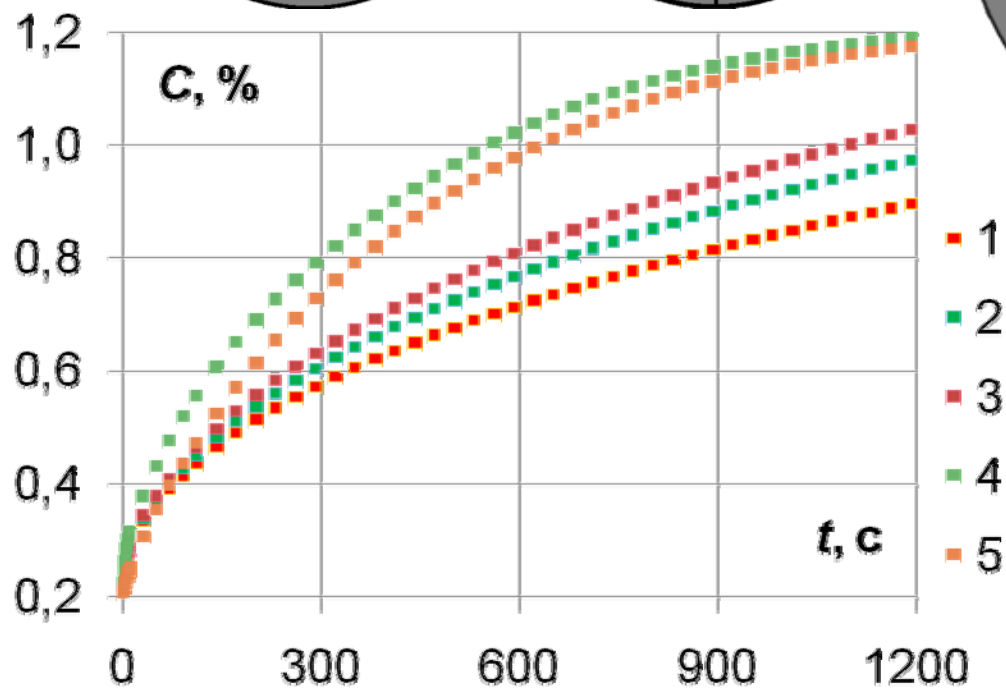
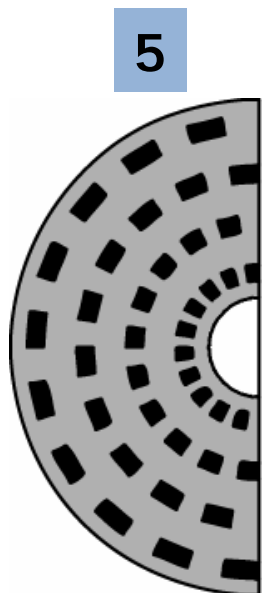
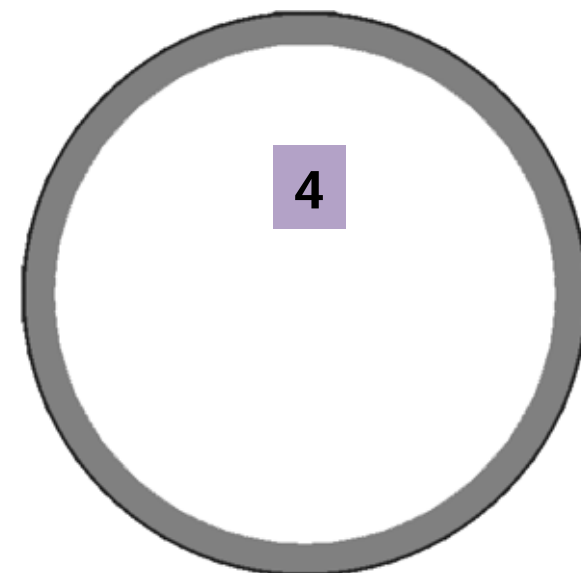
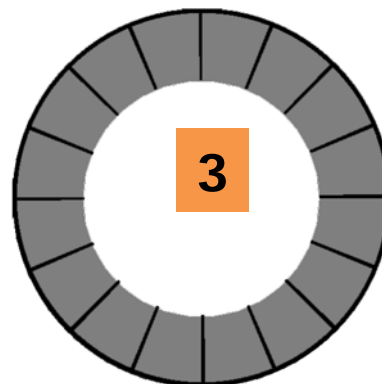
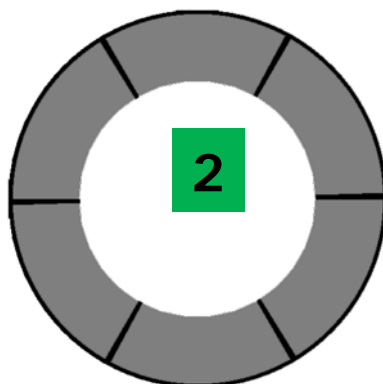
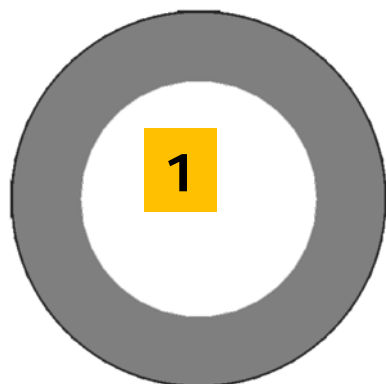

Reactor design optimization



PXO-3: shell and tube type reactor with outer and inner cooling of hydride bed inside tubular cartridges

Experimental cartridge PXO-5: outer wall is made from corrugated tube, combined water/air cooling is possible.



PXO-2: shell and tube type reactor with outer and inner cooling of hydride bed inside tubular cartridges



PXO-1: O-shaped capsules inside cylindrical casing with heat exchanger at outer wall

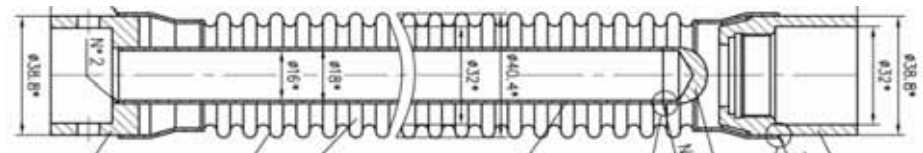
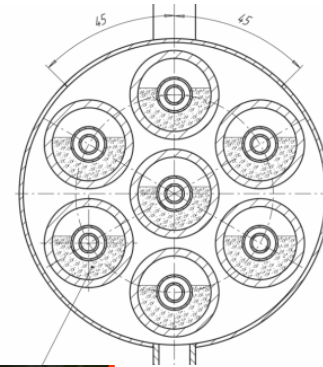

Comparative reactor tests

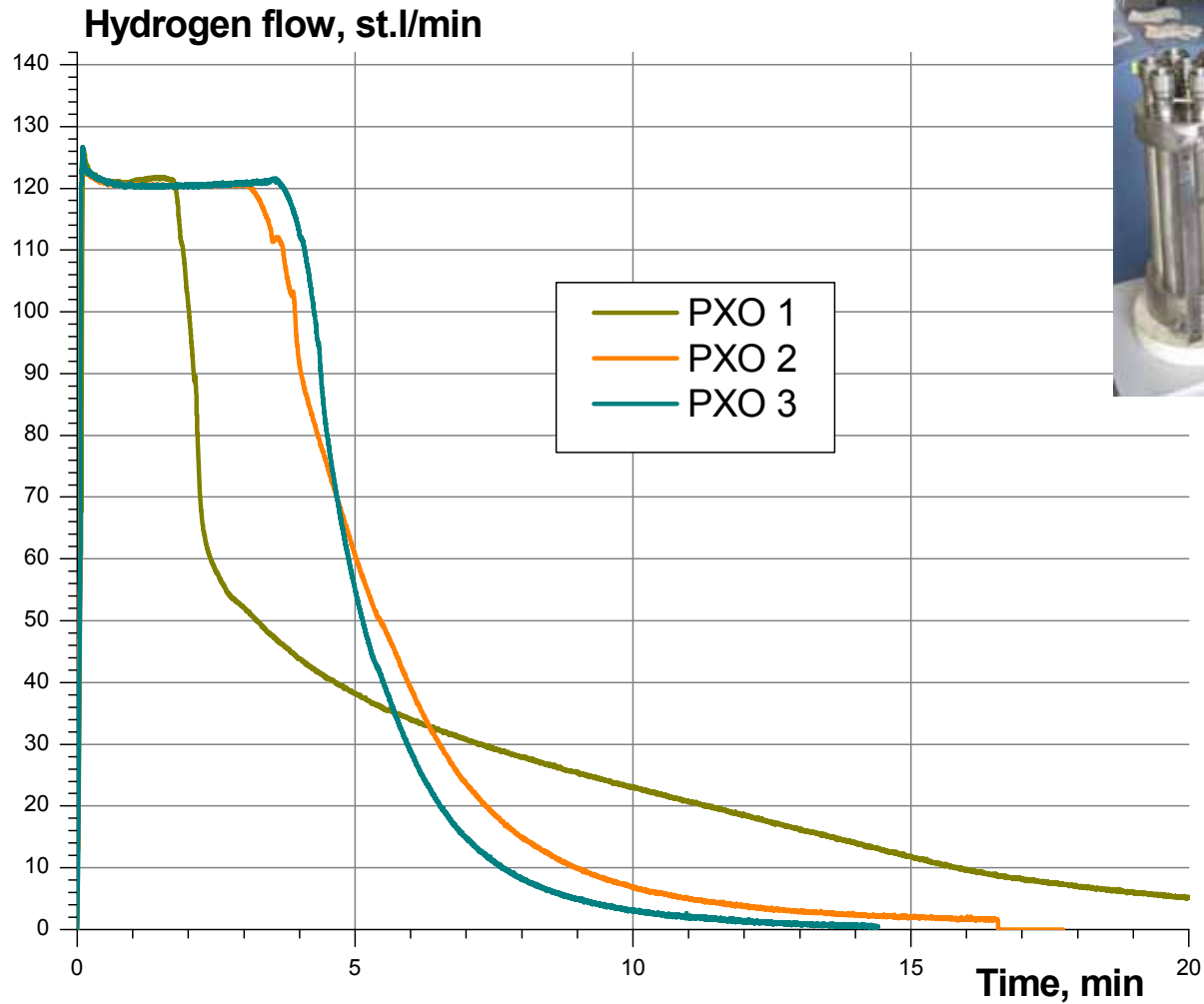

Pure hydrogen sorption at max. flow of 120 st.l./min

Impurities problem: experiment

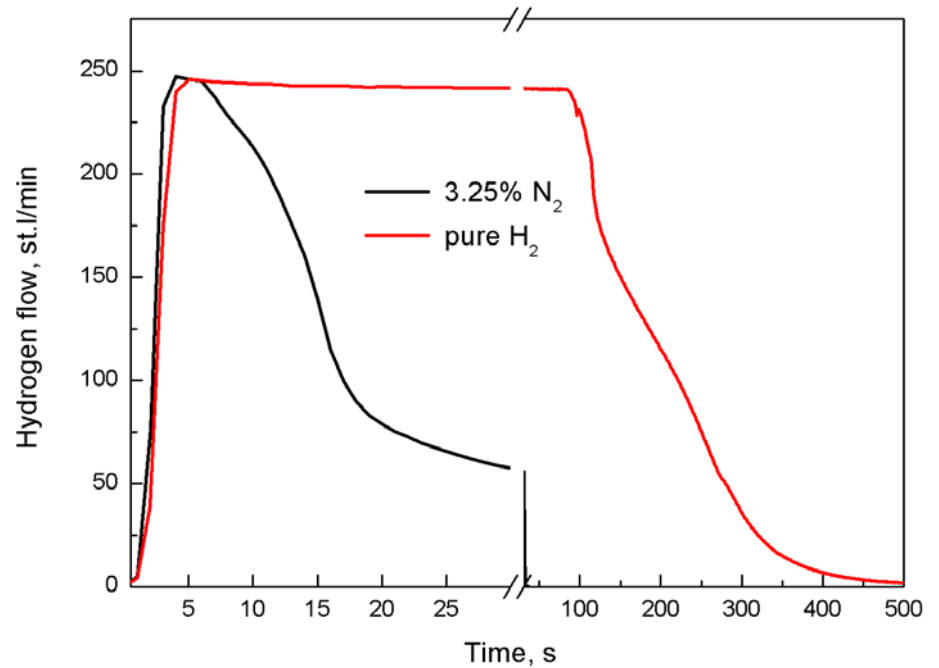
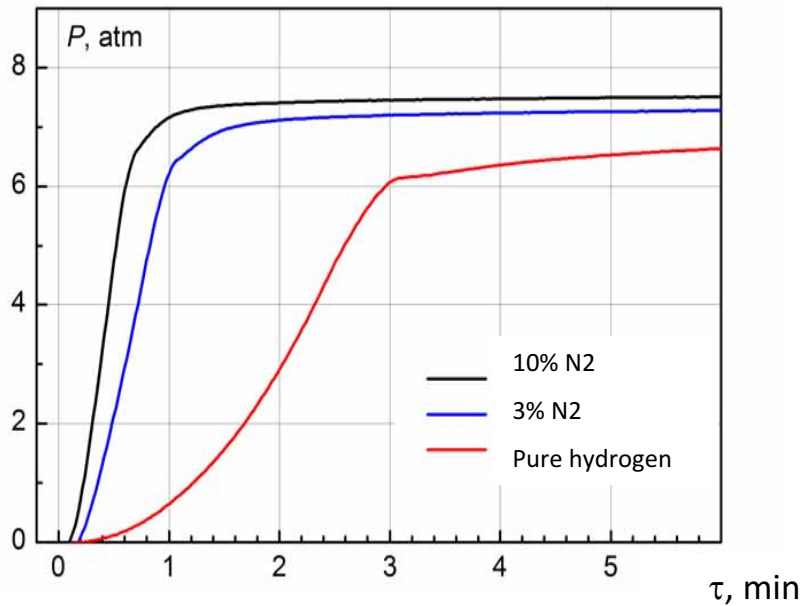

Pressure in the reactor (left) and hydrogen flow at inlet (right) at charging with pure and impure hydrogen

Admixtures concentrate in the reactor during a short period of time in the beginning of the process:
absorption rate is limited by hydrogen diffusion.

Hydrogen purification: experiment

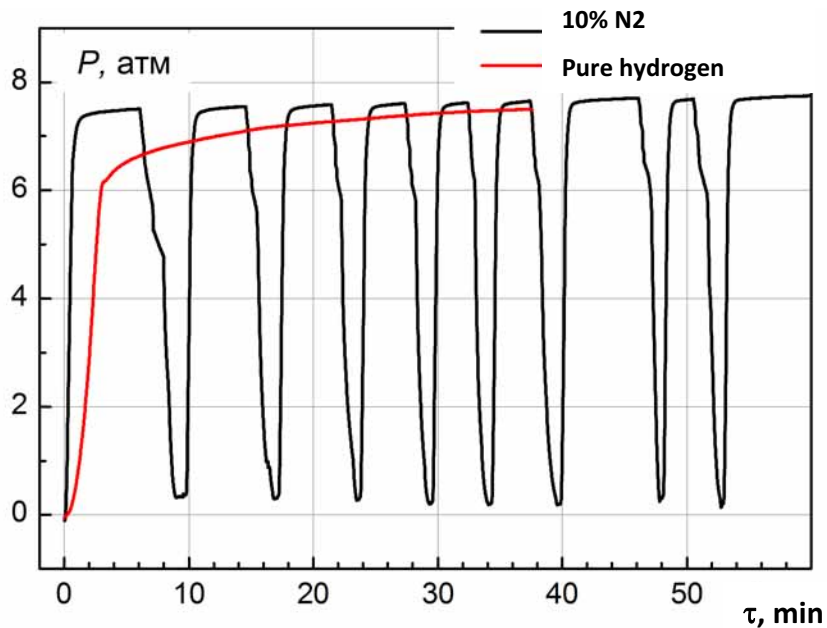

Pressure growth in the reactor at charging with pure and impure hydrogen

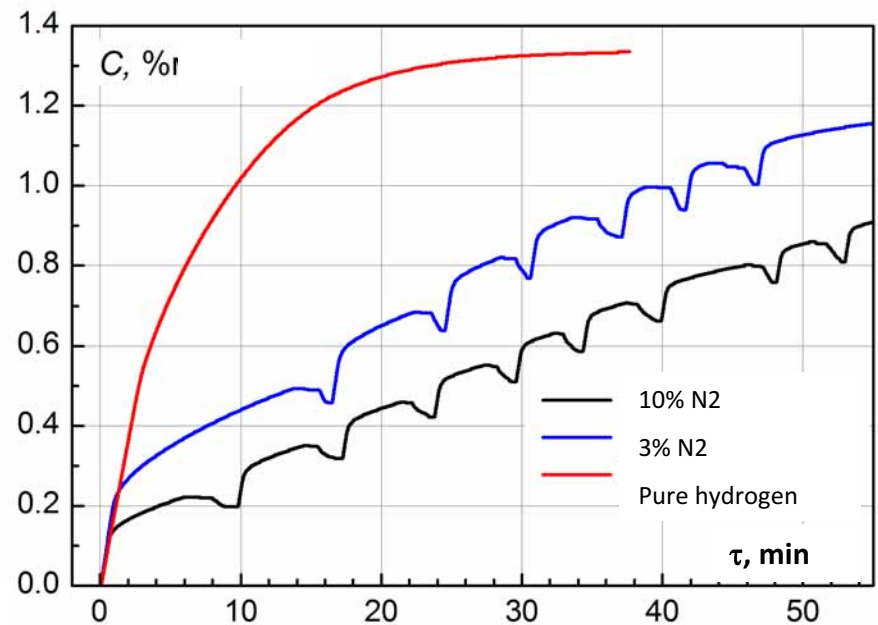

Time evolution of hydrogen mass content in the reactor for pure and impure hydrogen

PSA-like mode considerably increases the efficiency of the metal hydride reactor charging

Problem: hydrogen, cycling optimization required (PSA-like mode)

PSA-like mode optimization: admixture evacuation from spare volume of reactor

Regarding final pressure

Regarding period

Regarding flow

Hydrogen purity

to 99.95% (PEM FC requirement)

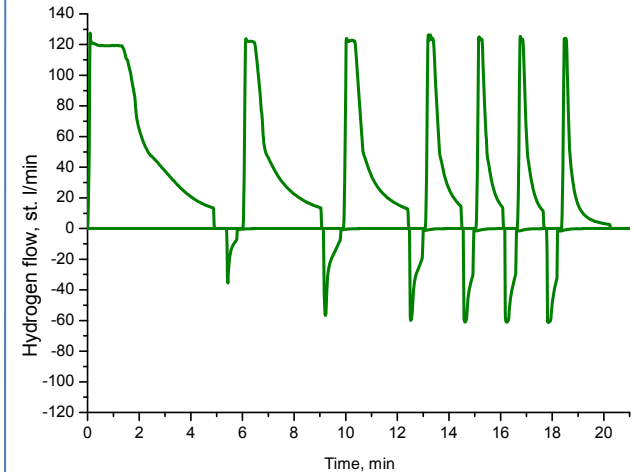
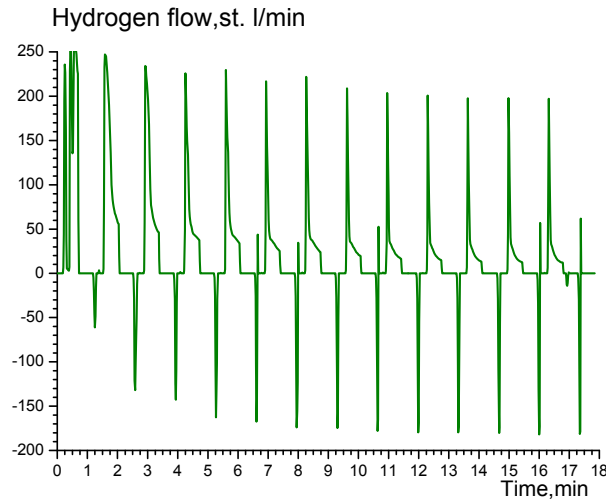
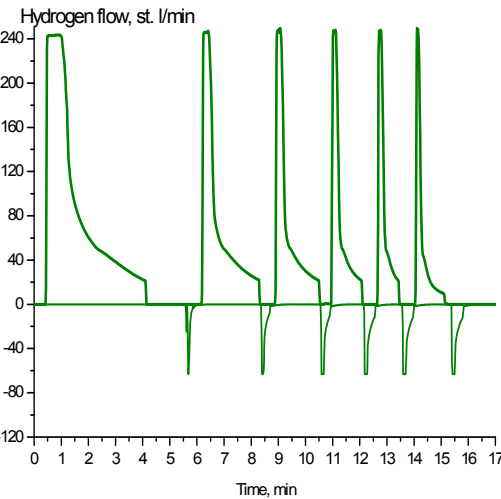

Hydrogen losses

up to 23 % of total flow

Materials: development of AB₅ alloys with optimized properties

Charge: 25 °C, 0.66 bar

MH purification



Discharge: 80 °C, 7.6 bar

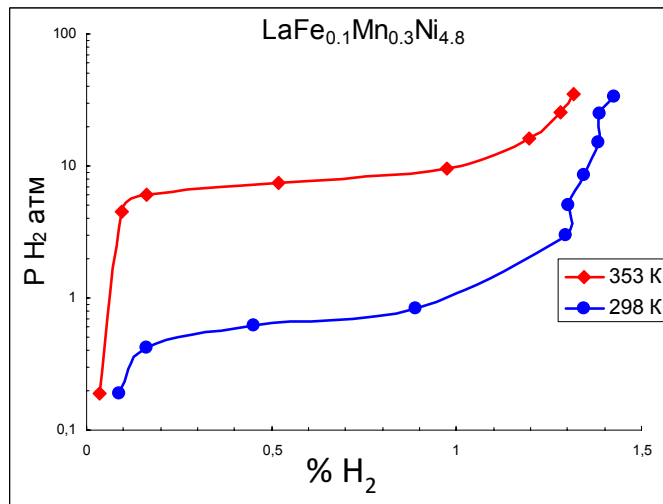

Charge: 25 °C, 1.1 bar

Hydrogen storage

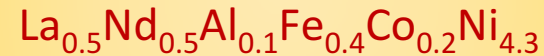

Discharge: 80 °C, 11.6

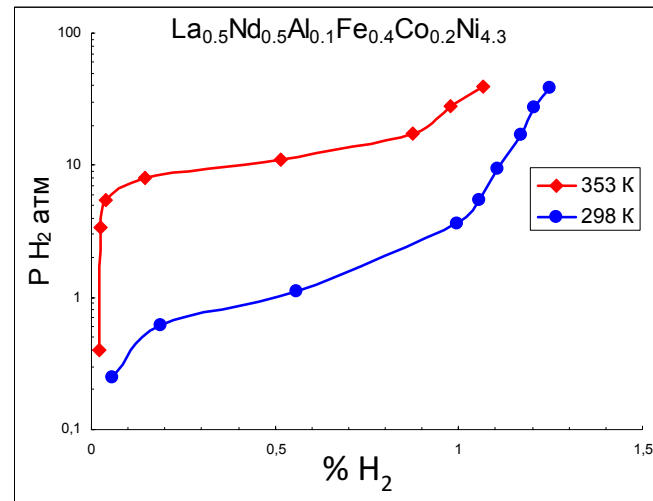

Fuel Cell

Inlet pressure
4.4 – 6.5 bar

Metal hydride storage tank integration with PEM FC

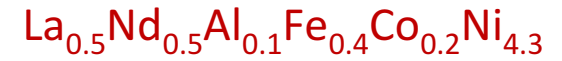
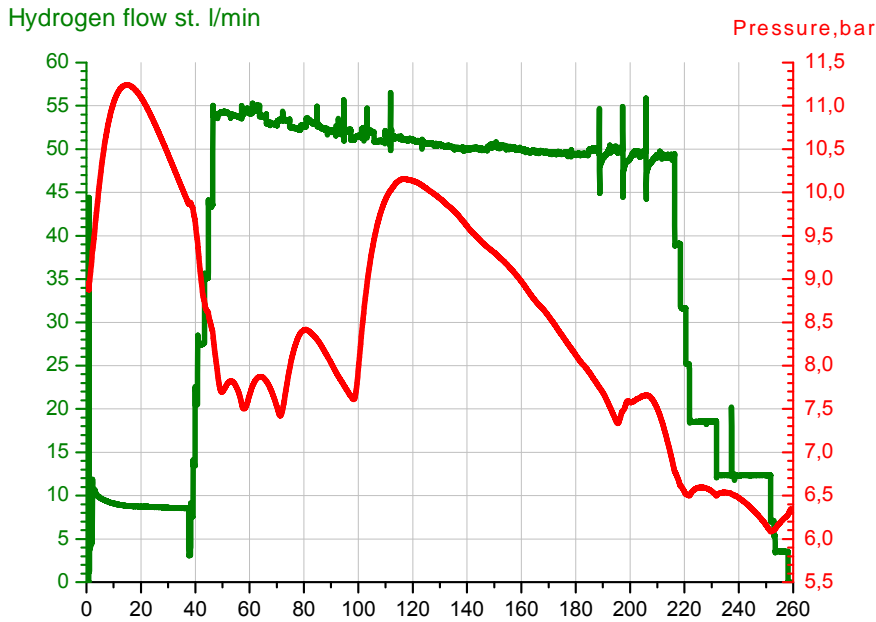

PX1: shell and tube type reactor with inner cooling of hydride bed inside tubular cartridges, natural or forced air convection outer cooling, 81 kg of alloy.

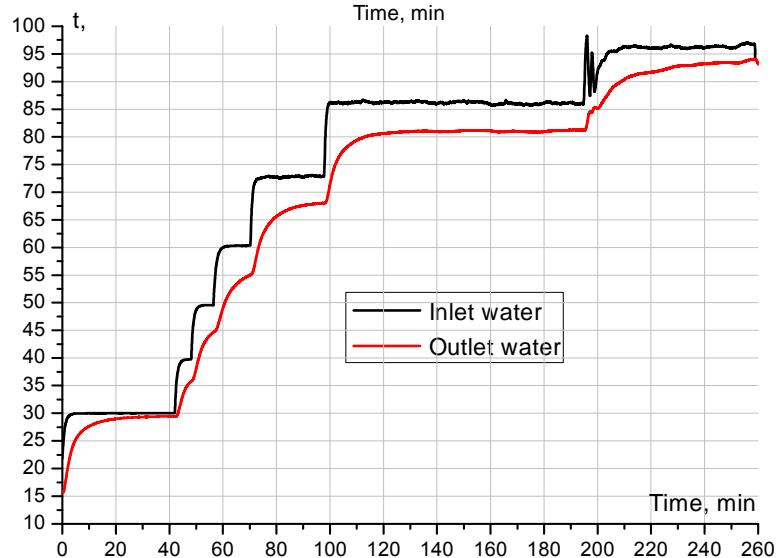

Metal hydride storage tank integration with PEM FC

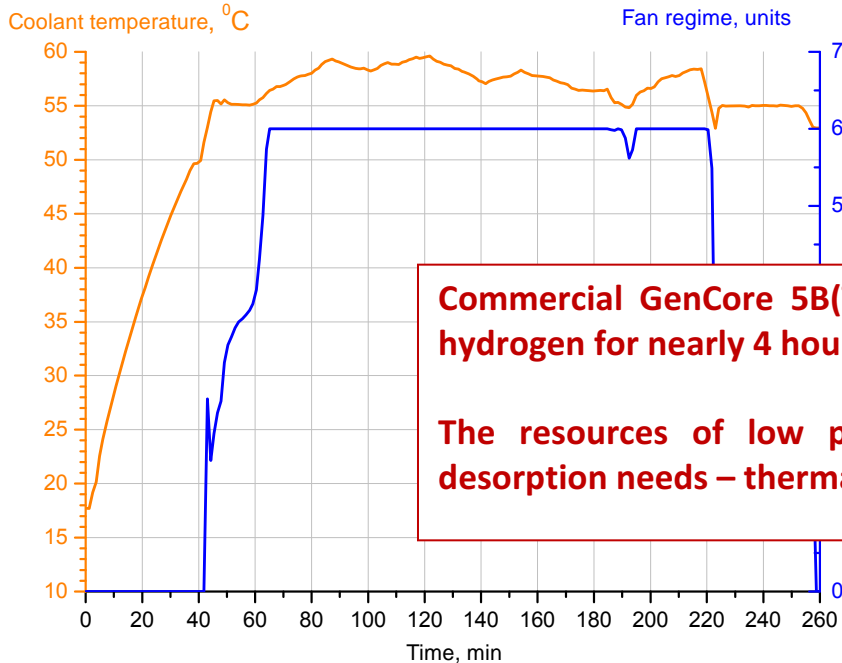
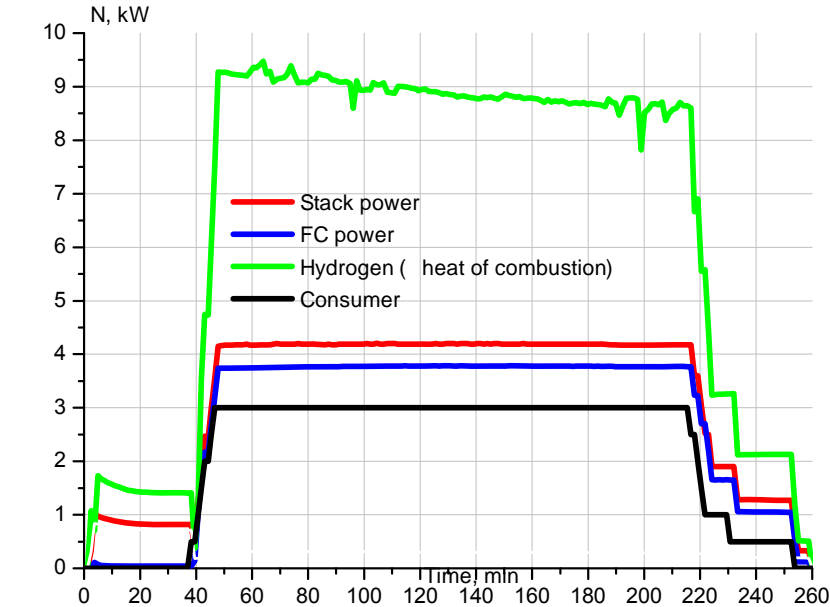

Commercial GenCore 5B(T)48 Fuel Cell system was successfully supplied with hydrogen for nearly 4 hours with total hydrogen volume of up to 12 m³

The resources of low potential heat (FC coolant) cover the storage tank desorption needs – thermal integration is possible.

Reversible solid state hydrogen storage and purification system for 5 kW FC supply: demonstration stage

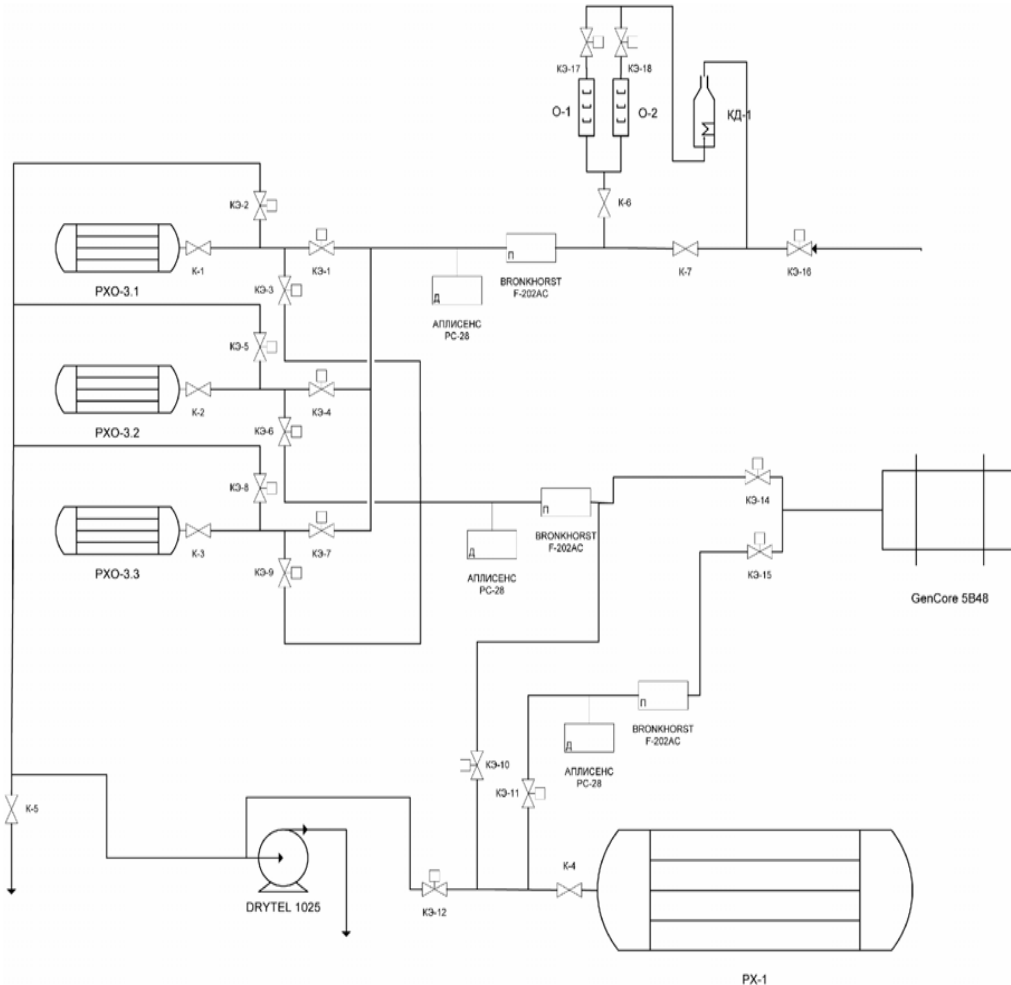

Conclusions

The peculiarities of heat and mass transfer processes in fine-dispersed porous beds of solid hydrogen absorbing materials were studied both theoretically by modeling and experimentally in model reactor

Reactor optimization on the base of developed 3D heat and mass transfer model was carried out and new types of reactors with enhances thermal characteristics were created

The feature of selective hydrogen sorption from hydrogen containing gas admixture was used for the creation of metal-hydride purification system for use in variable applications , PSA-like mode of purification was proposed and verified experimentally

The ways for MeH storage and purification units integration with PEM FC were studied and the opportunity for overall efficiency of the fuel supply system was shown

The possibility of system-scale utilization of traditional low temperature metal – hydrides (AB_5) in power production units was experimentally proved

International cooperation: supported by FASI



“Development of multipurpose reversible solid state hydrogen storage system with the participation of Swiss scientific research organizations”

Keywords: hydrogen absorbing materials and their properties, methods for property analysis, hydrogen purification

University of Geneva – National Centre of Competence in Research



“Problem targeted research and scientific reserve development in the field of energy saving with the participation of South African research organizations”

Keywords: solid-state hydrogen storage, thermally-driven hydrogen compression, heat management, hydrogen separation and purification

South African Institute for Advanced Materials Chemistry at the University of the Western Cape-HySA Systems-Systems Integration & Technology Validation - Competence Centre

International cooperation: IPHE project



Reversible Solid State Hydrogen Storage for Fuel Cell Power Supply System

Objectives:

Develop a reversible solid state hydrogen storage for PEM fuel cell power supply systems with advanced thermal system management, optimized power load modes and transient response;

- Develop a system model to simulate thermal and mass flows in FC power supply systems, including models of heat and mass transfer processes in hydrogen storage materials, and system and synergy effects in FC power supply operation;
- Create an experimental facility for complex investigation of heat and mass transfer in metal hydride devices and investigation of properties of hydrogen storage materials for development of standardized hardware and operating procedures, and applicable codes and standards for hydrogen storage systems;
- Develop new reversible hydrogen storage materials to meet IPHE targets.



Future activities

	Planned investigations
Experimental investigations of heat and mass transfer in MH devices	<input type="checkbox"/> Thermal properties of MH beds <input type="checkbox"/> Purification optimization <input type="checkbox"/> Size and scale effects
Mathematical modeling of processes in MH devices	<input type="checkbox"/> Model verification with experimental data
New materials	<input type="checkbox"/> Optimized alloys for specific applications
Reactor design and testing	<input type="checkbox"/> Dynamics and operation cycles of reactors <input type="checkbox"/> Optimized reactors for specific applications
System integration	<input type="checkbox"/> Multipurpose integrated system (Electrolyzer – MH system – FC) <input type="checkbox"/> Hydrogen cooled turbogenerators <input type="checkbox"/> Safety, standards and regulations

Laboratory for Hydrogen Energy Technologies Joint Institute for High Temperatures RAS



IVTAN

Izhorskaya 13 bld. 2

125412, Moscow

Russian Federation

Tel: +7(495)362-53-11

Fax: +7(495)362-07-84

h2lab@mail.ru

Thank you for your attention!