



RAS SAHT

*Alumohydrogen technologies
for remote consumers supply*

Alexander E. Sheindlin, Andrey Z.Zhuk, Eugeny J.Shkolnikov



Several problems of autonomous and centralized energy supply:

- Significant age of energy transferring and energy generating facilities;
- Remote areas where traditional energy transferring technologies have very high cost;
- Increase of mankind industrial activity influence on the ecological situation;
- Problems of power consumption and generation regulating in centralized grids;
- Ecological, technical and economical problems for new generating and transferring facilities construction in megapolises.

About 20 mln people in Russia live and work in areas lying outside of the centralized grid. In addition to improve ecology situation and quality of life for the whole population ecology-friendly and reliable base and back-up power sources are needed.



Why Aluminum?

Hydrogen is positioned as an ecology-safe and efficient fuel for future, but:

- Restrictions for the wide hydrogen application are exist. Most part of them is concerned with hydrogen transport, storage and distribution issues;
- H₂ specific energy is quite low under normal conditions;
- Hydrogen is combustive and leaky fuel;
- Electrolysis is quite expensive way of hydrogen production:
- Hydrocarbons reforming produces also CO and CO₂ and spends fossil fuels;

One of the ways to solve problem: ALUMOHYDROGEN TECHNOLOGIES – utilization of aluminum to generate hydrogen and/or electricity and heat “on demand” in place of consumption using relatively cheap and ecologically friendly raw materials



Alumohydrogen energy concept

Power plant



Excessive energy (night consumption fall)



Al production plant



Storage and transportation



For regeneration

Al OOH

Raw material



Fuel cells



Ceramic, catalysis, pharmacology factories



Electricity to the consumers

Heat to consumer



Hydrogen for consumption

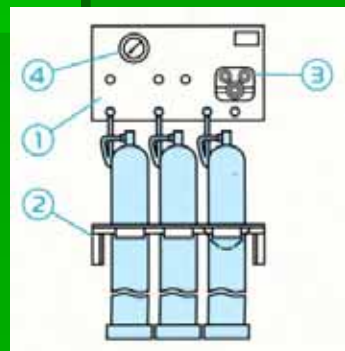

boiler + steam turbine



H₂ + steam

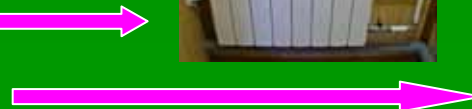

H₂





SAHT RAS alumohydrogen systems potential applications

Co- and trigeneration power plants. Production of heat, boehmite and hydrogen for niche applications



Magnetic hydrodynamic generators with alumohydrogen plasma sources. Power regulation for centralized grids

Compact hydrogen generators for transport and back-up applications



Hydrogen microgenerators coupled with fuel cells for portable applications





Back-up, emergency and uninterrupted power supply systems



(State contract № 02.516.11.6115)

Al – 0,7 kg/h, water – 2,8 м3/h (for 1 kWe without water recuperation)



30-54 V -



220-380 V ~

48-120 V -

380 V ~



Applications: back-up and emergency power for recreation objects, hospitals, railway and telecom automation and telemechanics



Compact hydrogen generators

2007-2008 : Hydrogen generator prototype for 1.2 kWe FC developed and tested (State contract № 02.516.11.6115)

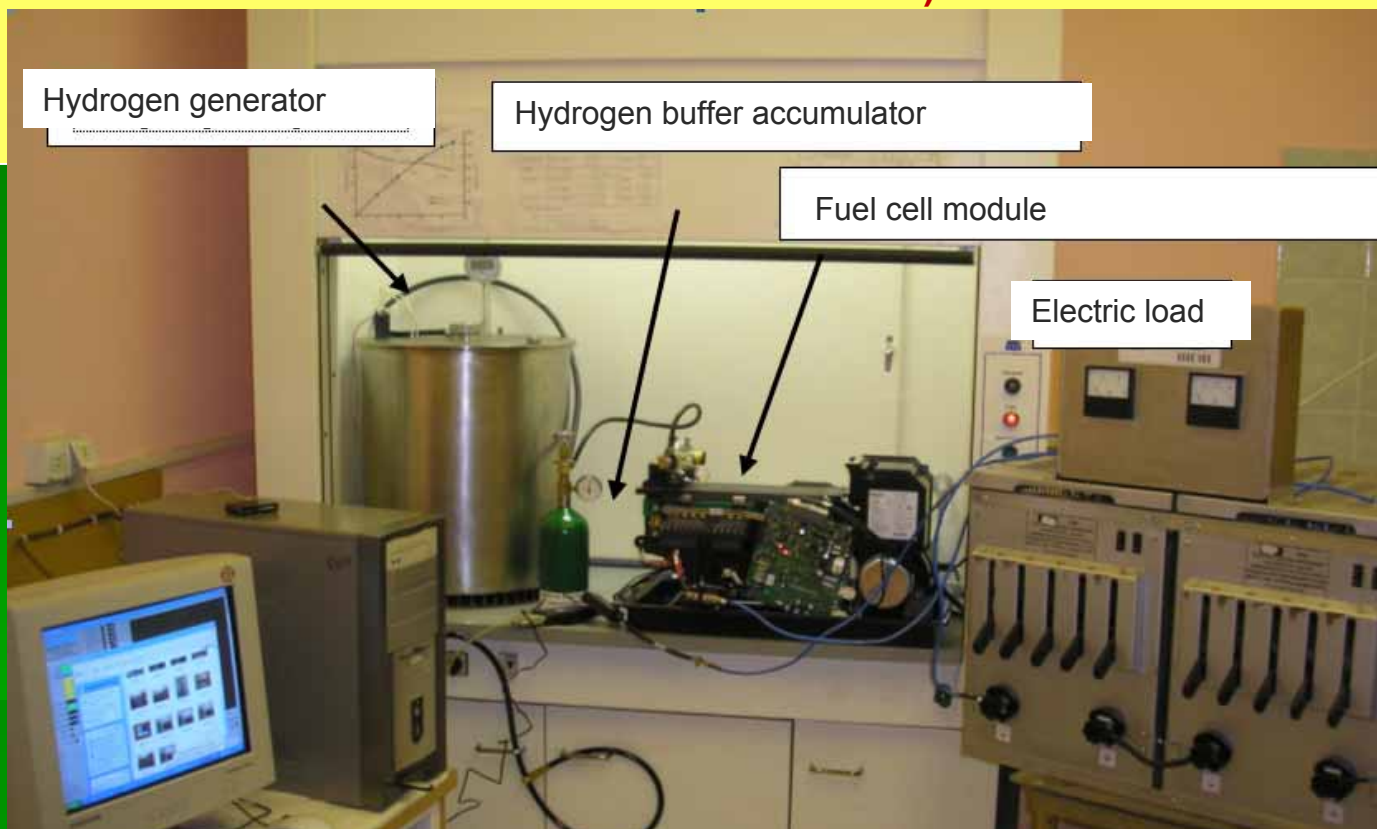

Further investigation directions:

-Industrial AI and secondary AI usage

-AIOOH regeneraton investigation (in this case energy costs are close to ones for diesel-generator)



State contract № 01.526.12.6010



Technical parameters:

CHP-10

Hydrogen production rate – 10 nm^3/h ,
Electric power output – 10 kW ,
Heat power output – not less than 18 kW ,
Fuel energy utilization coefficient –
not less than 60 %,
AIOOH (reaction by-product) production rate –
about 16 kg/h .

ETK-100

Hydrogen production rate – 100 nm^3/h ,
Heat power output – not less than 180 kW ,
Fuel energy utilization coefficient –
not less than 60 %,
AIOOH (reaction by-product) production rate –
about 160 kg/h .

World AIOOH market

More than 1 000 000 t/year only as raw
material for ceramics

Former Soviet Union countries: up to
100 000 t/year



Hydrothermal oxydation reactor:

Input

Al H₂O
m + α×m

α – water per Al mass unit

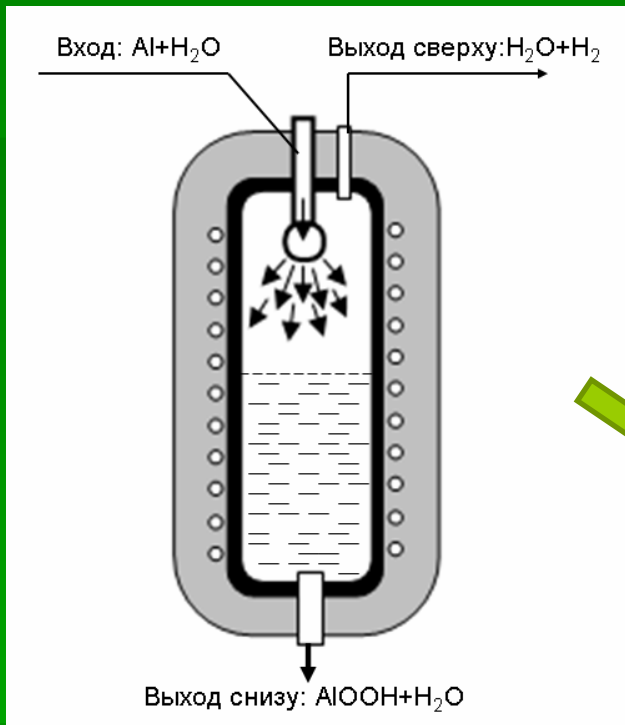

Output

top bottom

AlOOH m' m'' H₂

m + α×m

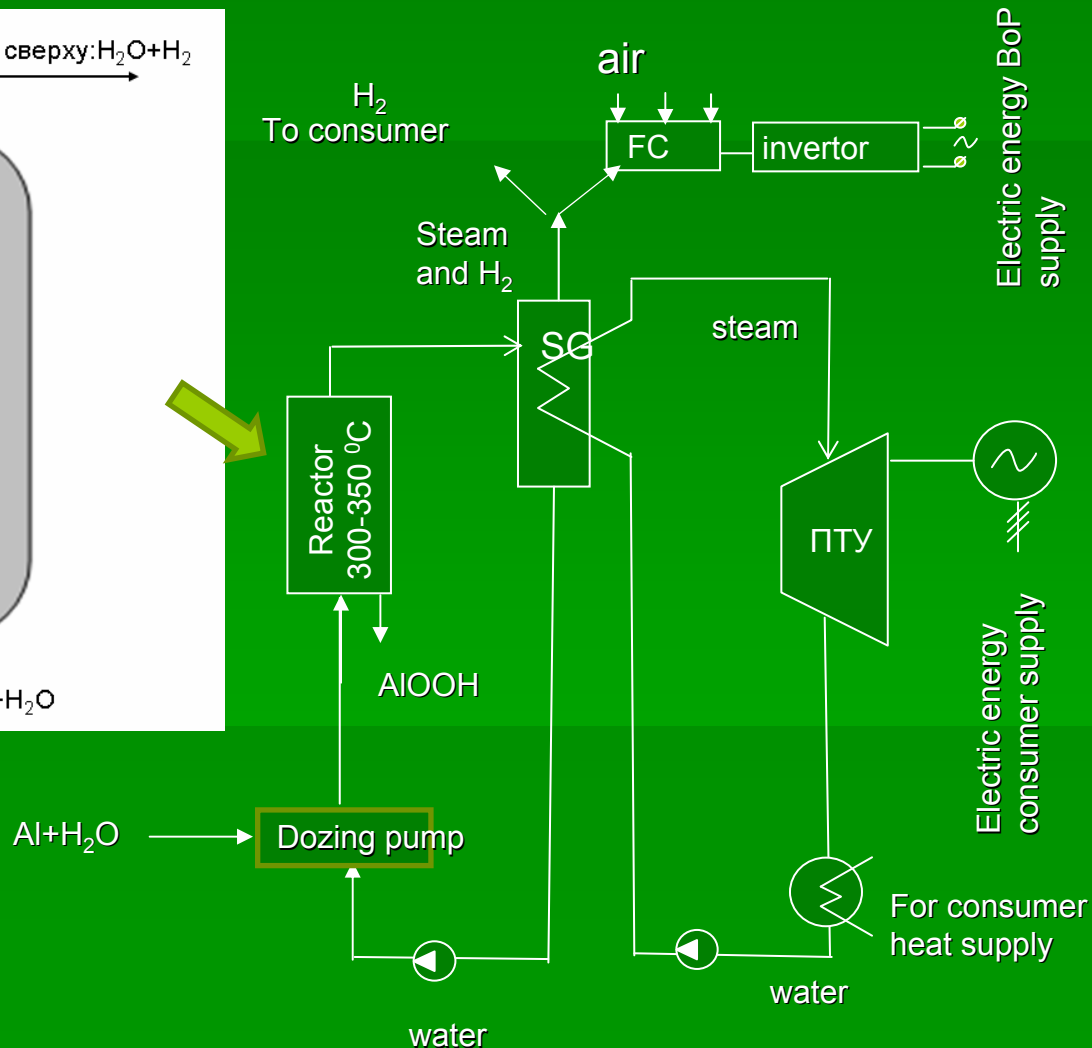



AlOOH application

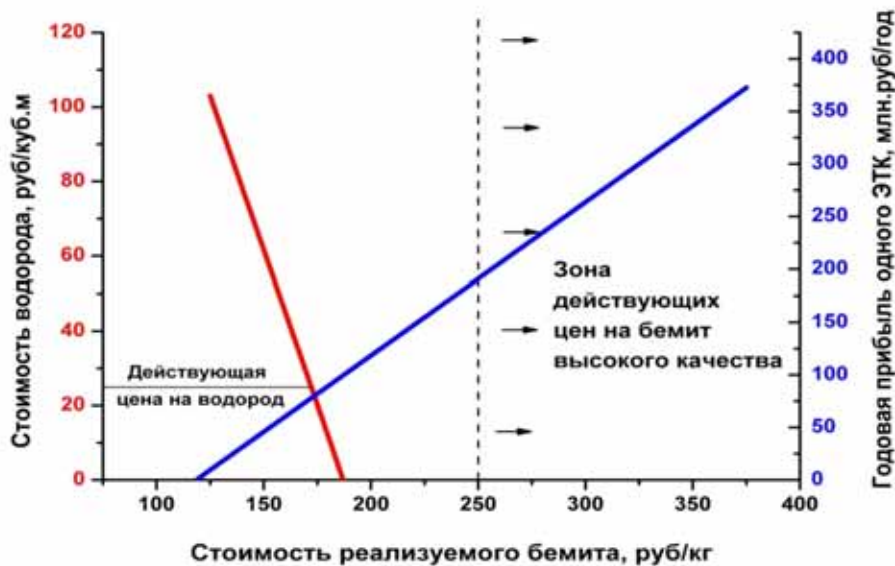

Realization of high quality expensive AlOOH leads to zero costs for energy and hydrogen

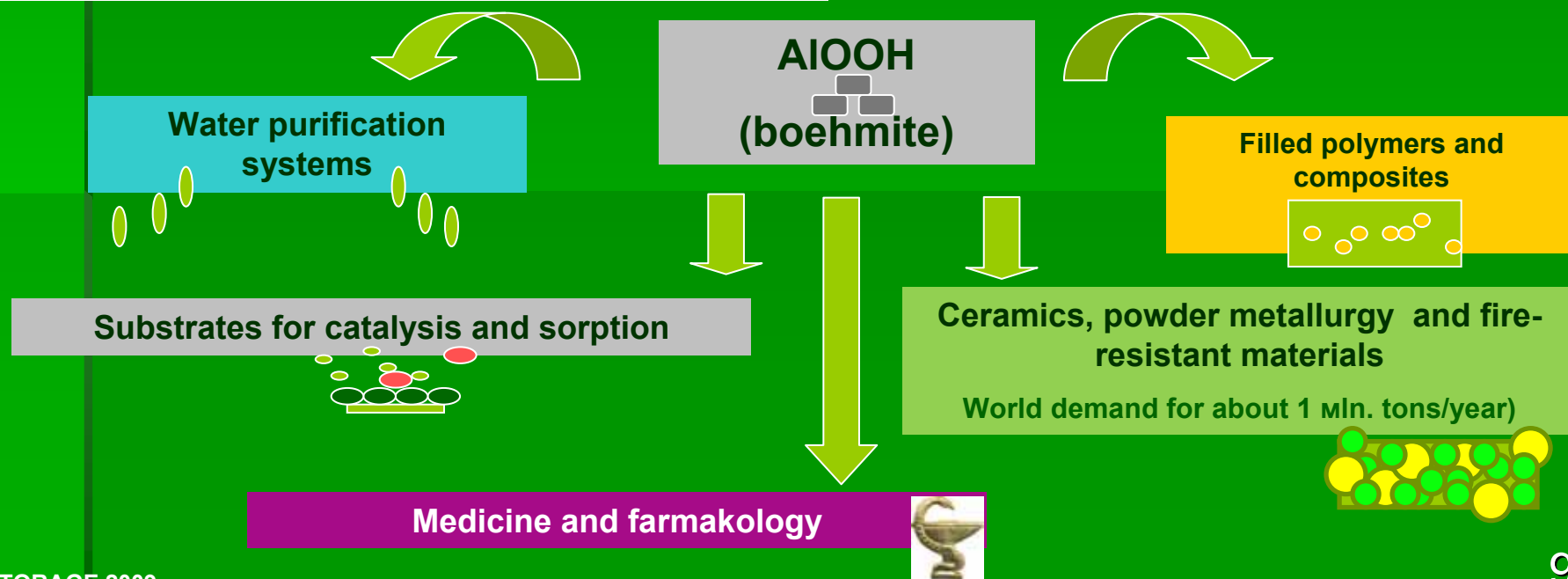



Heat supply projects based on ETK



Objects in megapolyses

Problems:

- Ecology issues
- Low noise level is needed
- Transferring facilities construction is too expensive



Solution– ETK application:

- Wastes – water vapors with low amount of NOx
- System needs only AI and is grid-independent

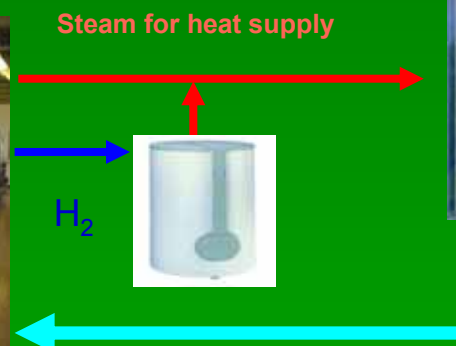

Water recuperation (condensation)

Reserve heat supply



Base stations for heat supply – gas powered boilers

Reserve fuel now – heavy oil fractions:

- Permanent heating needed;
- Large amount of auxiliary systems;
- Low shelf life – about a year;
- Ecology issues.

AI advantages:

- Long shelf life;
- Operational staff decrease;
- BoP systems decrease;
- Wastes decrease.



Al-H₂ MHD generators for centralized grid generation regulating

MHD-generator for peak power of 20-100 MW:

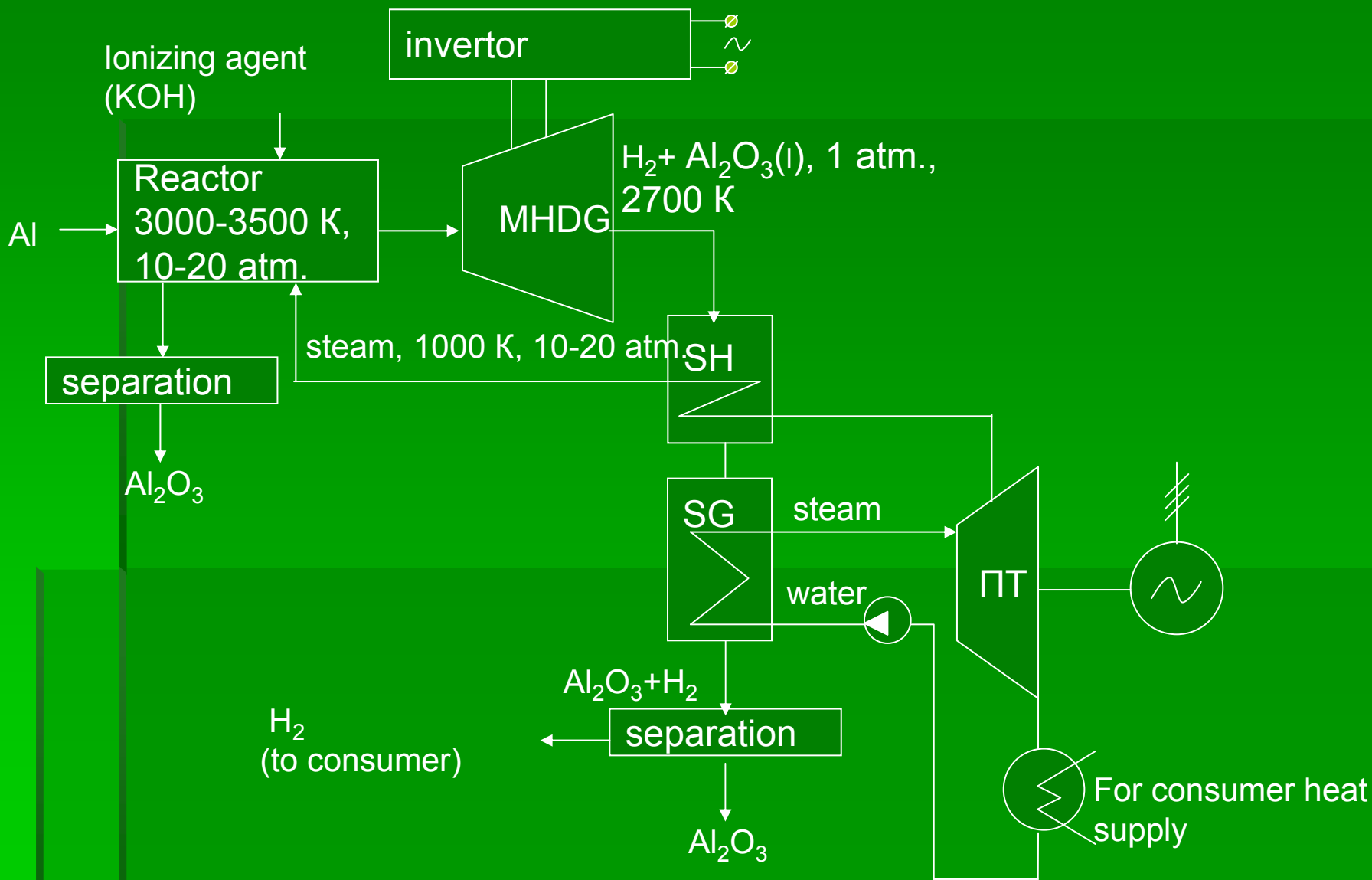



Direct Al conversion to electric energy

Al-air fuel cell and small-scale energy products



2-compartment Al-air FC

Salt electrolyte



Kr FC-powered lamp



Зарядное устройство

Alkaline electrolyte



Back-up 1,5 kW generator



Hybrid transport power source based on AA FC and lead-acid accumulators, single run increase from 50 to 250 km



Hybrid transport power source based on AA FC, lead-acid batteries and supercaps



Conclusions

- **Alumohydrogen systems have niches in the fields of back-up and emergency power, autonomous power units, portable units, hydrogen infrastructure and power regulating.**
- **Prospective niche is heat supply for objects in megapolyses and alternative to heavy oil reserve fuel for gas boilers in centralized heat supply.**
- **High-quality AlOOH-based products can be considered as a new product which increase power plants economic efficiency.**

These projects were supported by Russian Federal Agency for Science and Innovations and Russian Academy of Sciences Presidium Program

***Thank you for your
attention!***