



Moscow Power Engineering Institute (Technical University)

Klimenko A.V., Kuleshov N.V., Malysenko S.P., Fateev V.N.

Education and Science in the Area of Hydrogen Energy at the MPEI (TU).

October, 28, 2009

HYSTORY

Moscow Power Engineering Institute has long-standing traditions in the field of power engineering, including hydrogen energy. New hydrogen technologies for perspective energy are connected with names of academicians Kirillin V.A., Sheindlin A.E., Styrikovich M.A. (60-70-th years).

In accordance with the resolution of the Council of Ministers of the RF in 1964 Fundamental Research Laboratory “FUEL CELLS” was established at the MPEI. Academicians Frumkin A.N., Kolotyркиn Y.M. and Baraboshkin A.N. rendered big and invaluable help in establishment of Fundamental Research Laboratory.

For the first time training for the specialists in the field of hydrogen energy (specialisation “Hydrogen and electrochemical energy”) began in 1976 on the base of the chair of Chemistry and Electrochemical Energy (Dr. Korovin N.V.), which belongs to the Institute of Power Effectiveness Problems (Director -Corresponding Member of Russian Academy of Science – Klimenko A.V.)

HYDROGEN ENERGY

Electrolysis

Hydrocarbon conversion

H₂ Storage and transport
H₂ Purification and Division

Atomic hydrogen technologies

Direct use in engine

Ground transportation and use of H₂

With the use of fuel cells

Hydrogen systems at power engineering

Airspace technologies

Fuel Cell

The use of hydrogen at the real economics sector

BASIC DISCIPLINES of SPECIALIZATION

Base courses: physics, mathematics and chemistry.

Engineering courses: thermophysics, electrical engineering and electronics, power engineering, including modern plants, renewable energy, atomic energy, materiology (including porous and membrane materials) and etc.

Special courses: physical chemistry, electrochemistry, theory and technology of electrochemical and hydrogen power plants, ecology, protection against corrosion and etc.

Special attention is given to the preparation on computer and economy.



SOME DISCIPLINES of the SPECIALITY

Hydrogen energy

Fuel cells

Electrochemical current sources

Renewable energy

Electrochemical power plants

INTEGRATION WITH LEADING ENTERPRICES

- Educational-science center of MPEI (TU) and RSC “Kurchatov Institute” (РНЦ «Курчатовский институт») is created in 2001 .**
- Educational-science center MPEI (TU) and IHT of Russian Academy of Sciences (ОИВТ РАН) functions effectively.**
- Constant contacts: Institutes of RAS, Moscow State University, science industrial plants “Quantum“, «Red Star”, JSC “Alten”, and others.**

TEXTBOOKS

1. Shpilrain E.E., Malishenko S.P., Kuleshov G.G., Introduction in hydrogen energy, M., Nuclear energy publishing house, 1984;
2. Korovin N.V. Electrochemical generators, M., Energy, 1974;
3. Korovin N.V. New chemical current sources, M., Energy, 1978;
4. Shpilrain E.E., Malishenko S.P., Kuleshov G.G., Introduction in hydrogen energy, M., Nuclear energy publishing house, 1984;
5. Kuleshov N.V., Telnov V.P., Korovin N.V., Hydrogen energy. The ways of hydrogen production for power installations. MPEI, 1989;
6. Korovin N.V. Electrochemical energy, M., Nuclear energy publishing house, 1989;
7. Korovin N.V. Fuel cells and electrochemical power installations, MPEI, 2005;
8. Korovin N.V., Skundin A.M. Chemical Power Sources, Chemistry, 2006.
9. Kuleshov N. V., Grigoreiv S.A., Fateev V.N. Electrochemical power installations for hydrogen energy, MPEI, 2007 and others).
10. Kuleshov N. V., Fateev V.N., Osina M.A. Nanotechnology for the hydrogen power installations, MPEI, 2009.

GRADUATION of SPECIALISTS on HYDROGEN ENERGY

Integral graduation

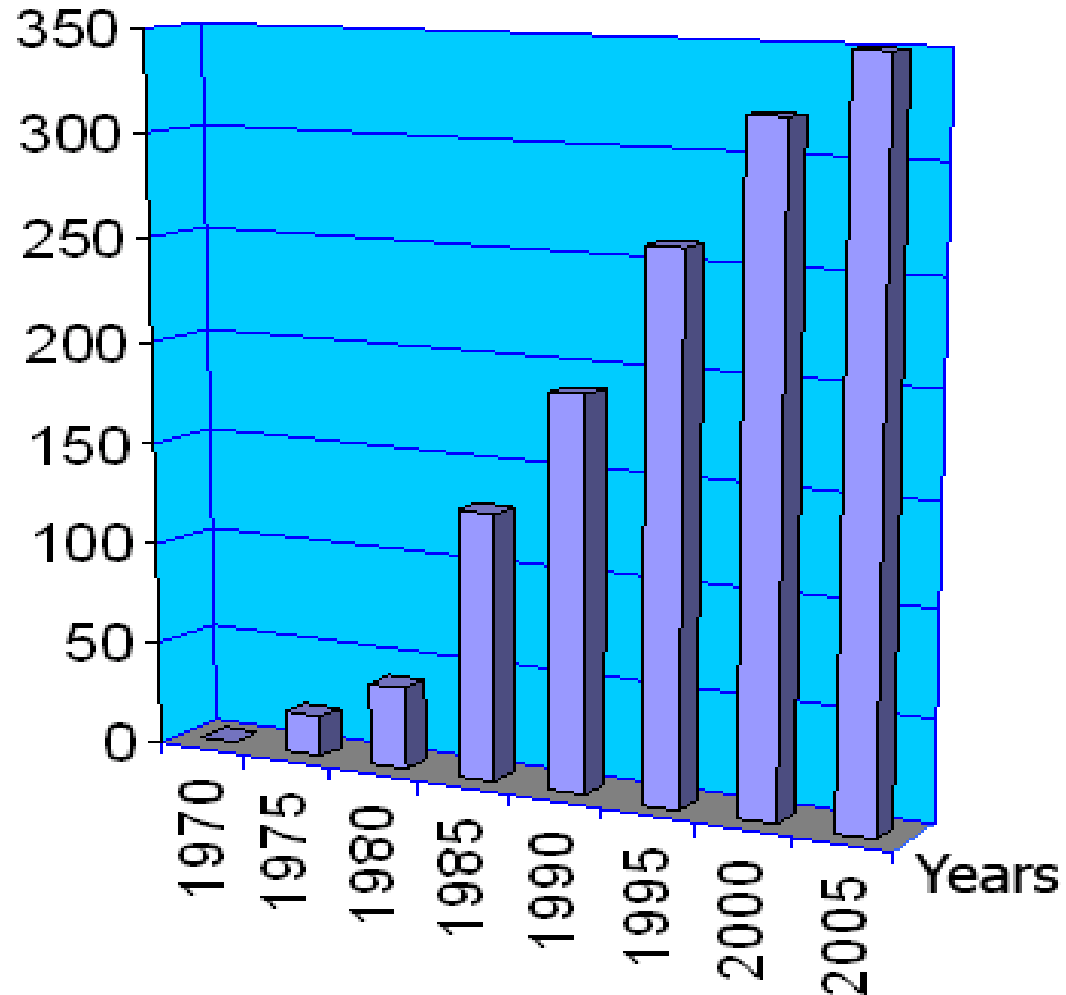

In the frames of Federal Targeted Program

**“ Scientific and Scientific-Pedagogical Persons of Innovation Russia”
on 2009 - 2013 years.**

1. Scientific - Educational Center (SEC) at MPEI (TU) (+ FTI named by A.F. Ioffe and Novosibirsk University centers) was created. The aim of the center is conduct of research by collective of SEC in the field of **creation of integral systems electrolyzer — metal-hydride system of purification and accumulation of hydrogen— fuel cell.**

Co-worker: RSC “Kurchatov Institute”

Special conditions – 50/50

- **2. Conduct of research by scientific group under head of Ph.D. –(1)**
- **3. Conduct of research by Ph.D. student - 1 (Bogomolova A.)**
- **4. Conduct of research by scientific group under head of invited researchers – 2 (Zubrin S. - England, Martem’jnov V. - France)**
- **5. Holding of international conference on Hydrogen Energy - 1**

INTERNATIONAL SYMPOSIUMS on HYDROGEN ENERGY

H₂



Международный симпозиум по водородной энергетике

МОИ  **Hydrogenics**

1 - 2 ноября 2005 года
МОСКВА

H₂

1-2 ноября 2007 г., Москва, Россия

ТРУДЫ II Международного симпозиума по водородной энергетике

Водородная энергетика: состояние, проблемы, перспективы
Получение водорода
Хранение и транспорт водорода
Водород в энергетике и на транспорте
Топливные элементы
Подготовка специалистов в области водородной энергетики

МОИ

INTERNATIONAL SYMPOSIUM on HYDROGEN ENERGY



INTERNATIONAL SYMPOSIUM on HYDROGEN ENERGY



OUR DIPLOMAS and PATENTS



3rd INTERNATIONAL SYMPOSIUM on HYDROGEN ENERGY



МЕЖДУНАРОДНЫЙ
СИМПОЗИУМ
ПО ВОДОРОДНОЙ
ЭНЕРГЕТИКЕ



INTERNATIONAL SYMPOSIUM ON HYDROGEN ENERGY

Moscow Power Engineering Institute (Technical University) is pleased to invite you to attend II International Symposium on Hydrogen Energy.

Dates: 1-2 December 2009

Location: MPEI, 14 Krasnokazarmennaya, Moscow, Russia.

Organizers and Sponsors:

Federal Agency on Science and Innovations of the Russian Federation
Moscow Power Engineering Institute (Technical University)
“Hydrogenics Co.”

Sections to be held within the scope of the Symposium:

1. Hydrogen Energy: State-of-the-art, Problems, Perspectives;
2. Hydrogen Production;
3. Hydrogen Storage and Transportation;
4. Hydrogen in Energy and Vehicles;
5. Fuel Cells (including portable);
6. Training of Experts in the Area of Hydrogen Energy;
7. Students Section.

The Symposium program will include presentations by leading Russian and foreign specialists in the area of hydrogen energy as well as master classes “Problems of Hydrogen Energy”.

Please submit the completed pre-registration form (see Appendix 1) before 16 May 2007 by e-mail: H2-symposium@mail.ru

Papers deadline is 1 July 2007. Presentations to be printed in the Symposium proceedings should be in the form of scientific articles from 4 to 6 pages. For more information and the requirements see our website: <http://www.h2-symposium.ru>.

The Center of Collective Usage (CCU) of Scientific Equipments « Hydrogen Energy and Electrochemical Technologies»

is opened in 2004, among 110 CCU in RF- it's single with name
“Hydrogen”

The center has it's own modern equipment, new scientific devices
and test beds in the field of hydrogen energy



MODERN EQUIPMENT of the CCU "HYDROGEN ENERGY AND ELECTROCHEMICAL TECHNOLOGIES"





"HYDROGENICS" EQUIPMENTS



SOME SUBJECTS OF SCIENTIFIC-RESEARCH EFFORTS, SPONSORED IN 2007-09

State contracts with RosScience in the frames of Federal Targeted Programs:

- "Research and development of technologies of creation of new generation elemental base and membrane-electrode blocks for low temperature water electrolysers and fuel cells"
- "Mathematical Models of Heat and Mass Transfer in Metal-Hydrides"
(G.Yankov)
- "Scientific-research efforts and development of reversible electrochemical system with polymer-electrolyte membranes, carrying out in the framework of international cooperation with the countries of European "

RosEducation: "Research of lithium current sources on the base of nanostructured materials"

Russian Fund of Fundamental Researches:

- "Development of electrode-diaphragm blocks for alkali electrolysis on the base of new composition polymeric diaphragms and catalytically active electrodes"
- "Research of kinetics and mechanism of biocatalytic reduction of inorganic and organic hydroperoxides on nanostructured composite materials: enzyme conducting polymeric-carbon carrier"

Economic contracts:

- RSC "Kurchatov Institute" – "Research and development of high efficient electrolytic systems with polymer-electrolyte membranes"
- "UralChemMash"- "Development of alkali water electrolysers"
- NAVE – "Determination of effect of hydrogen addition to the traditional fuel engines on technical and economical characteristics of automobile"

THE FIELDS OF ALKALINE HYDROGEN CONSUMPTION

Food industry. The main usage is fat hydrogenation. Industry is directed for large scale installations ($\Phi B250$).

Metallurgy. Metal extraction by direct ore reduction method (electrolysers $\Phi B 500$), and hard metal preparation.

Electronic industry. Usually hydrogen is used for creation of deoxidizing atmosphere in the epitaxial processes (CЭY40)

Power engineering. Hydrogen is used for high-power turbogenerator cooling, owing to it's high thermal conduction and diffusion constant, and as well it's non toxicity. (CЭY10-20)

Glass industry is the main consumer of electrolytic hydrogen. It's plants are the traditional glass suppliers of domestic car and aircraft industries, and they constantly expand the range of goods. (CЭY40)

Near prospects. Necessity of electrolytic hydrogen production increasing is a result of it's traditional consumer development and also new consumer appearance, such as auto transport, cosmonautics, fuel cell power installations, power plants and systems of conversation, based on renewable energy and etc.

ELECTROLYSIS INSTALLATIONS OF JSC “URALCHEMMASH”

- **At present more than 1500 domestic and foreign plants use electrolysis installations of JSC “UralChamMash”.**
- **Up to 1990 JSC “UralChemMash” supplied electrolysers to 30 foreign countries.**
- **After 1990 deliveries of JSC “UralChemMash” decrease dozen of times.**
- **After 2000 Russia from country-exporter of electrolysis installations turns into importer.**

ASSEMBLY OF ELECTROLYSIS INSTALLATIONS AT THE JSC "URALCHEMMASH"



TECHNICAL AND ECONOMICAL CHARACTERISTICS OF ELECTROLYSERS, PRODUCED BY JSC "URALCHEMMASH"

Characteristic and overall dimensions	Electrolyser type			
	СЭУ-4	СЭУ-10	СЭУ-20	СЭУ-40
Working pressure, MPa	1(10)	1(10)	1(10)	1(10)
Workspace temperature, °C	+80	+85	+85	+90
Voltage, V	72	78	100	200
Pure product content, %				
Hydrogen	99,0	99,0	99,7	99,7
Oxygen	98,0	98,0	99,5	99,5
Volume output, M3 per hour:				
Hydrogen	4	12	20,5	41
Oxygen	2	6	10,25	20,5
Overall dimensions, mm				
Length	1700	2050	2400	4100
Width	610	915	1060	1060
Height	830	1080	1780	1785
Electrolyser mass, kg	1290	3032	4720	7435
Electrolyser and fitting mass, kg	10578	19430	23390	27335

ELECTROLYSERS OF JSC "URALCHEMMASH"

Merits

&

Demerits

- **Reliable design**
- **Operating simplicity**
- **Long service life**

- **High power consumption**
- **Absence of electrolysis automatic production**
- **High mass-overall dimensions**
- **Asbestos diaphragm**

ALKALI ELECTROLYSIS

The aim:

To decrease energy consumption up to 4,1 kW-hour/M³ owing to development of MEA, optimization of heat-mass exchange process in electrolysis elements and electrolysis installation, without use of precious metals and asbestos.

NEW ADVANCED CATHODES

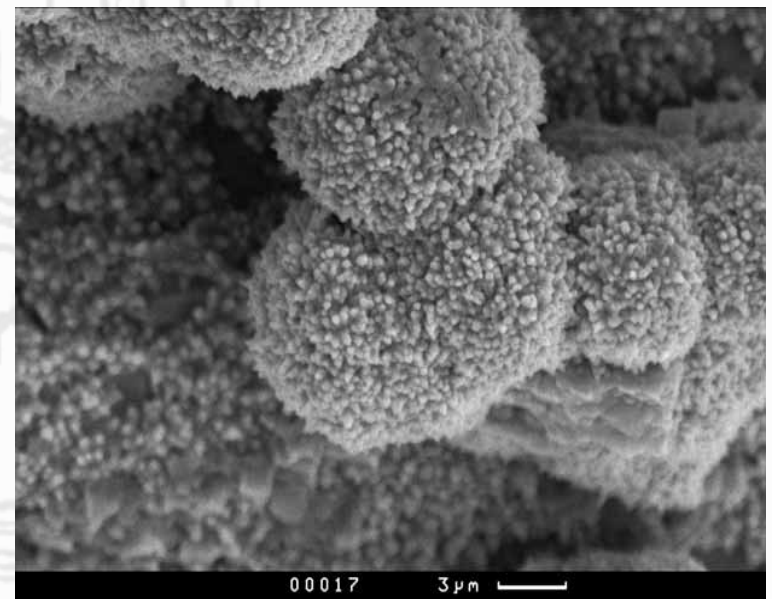
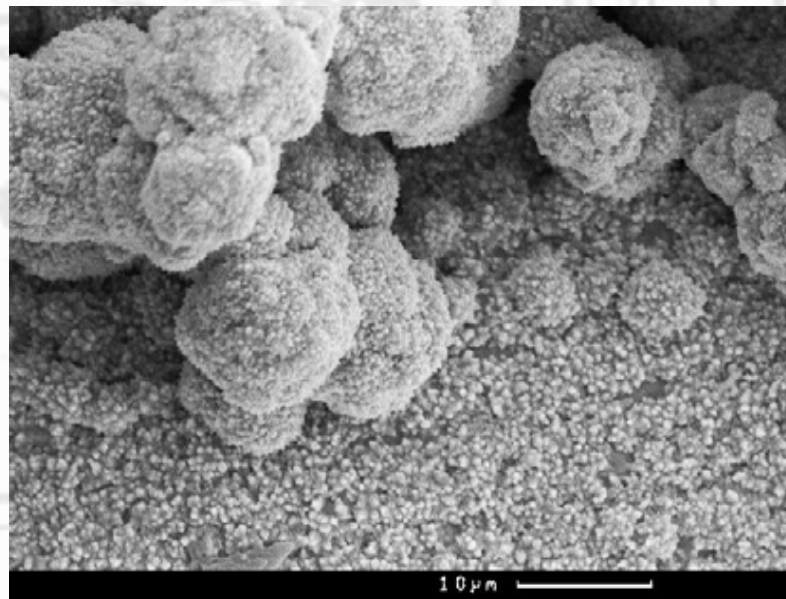
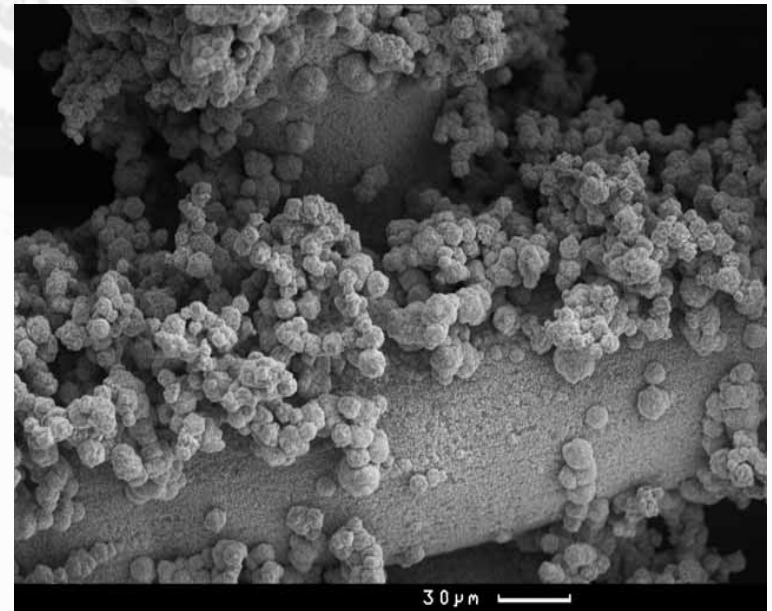
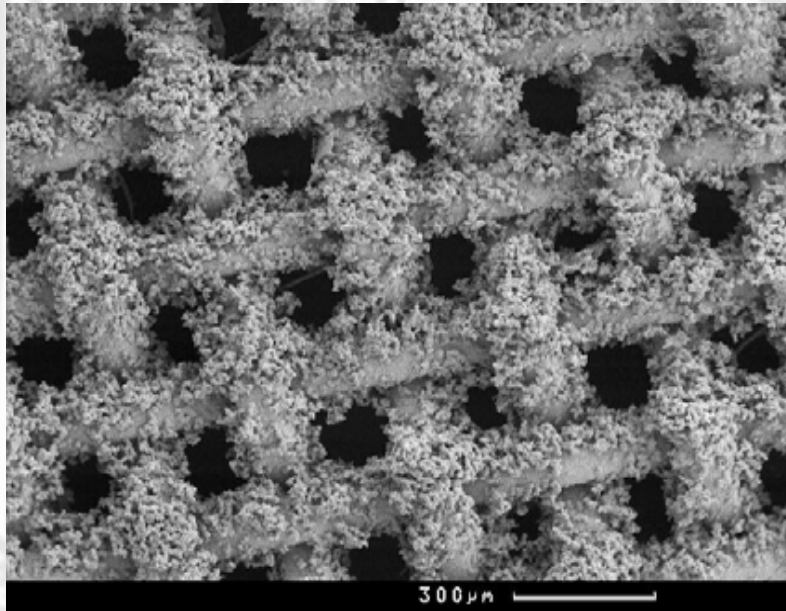

CURRENT-VOLTAGE CURVES OF ANODIC MATERIAL IN 6 M KOH

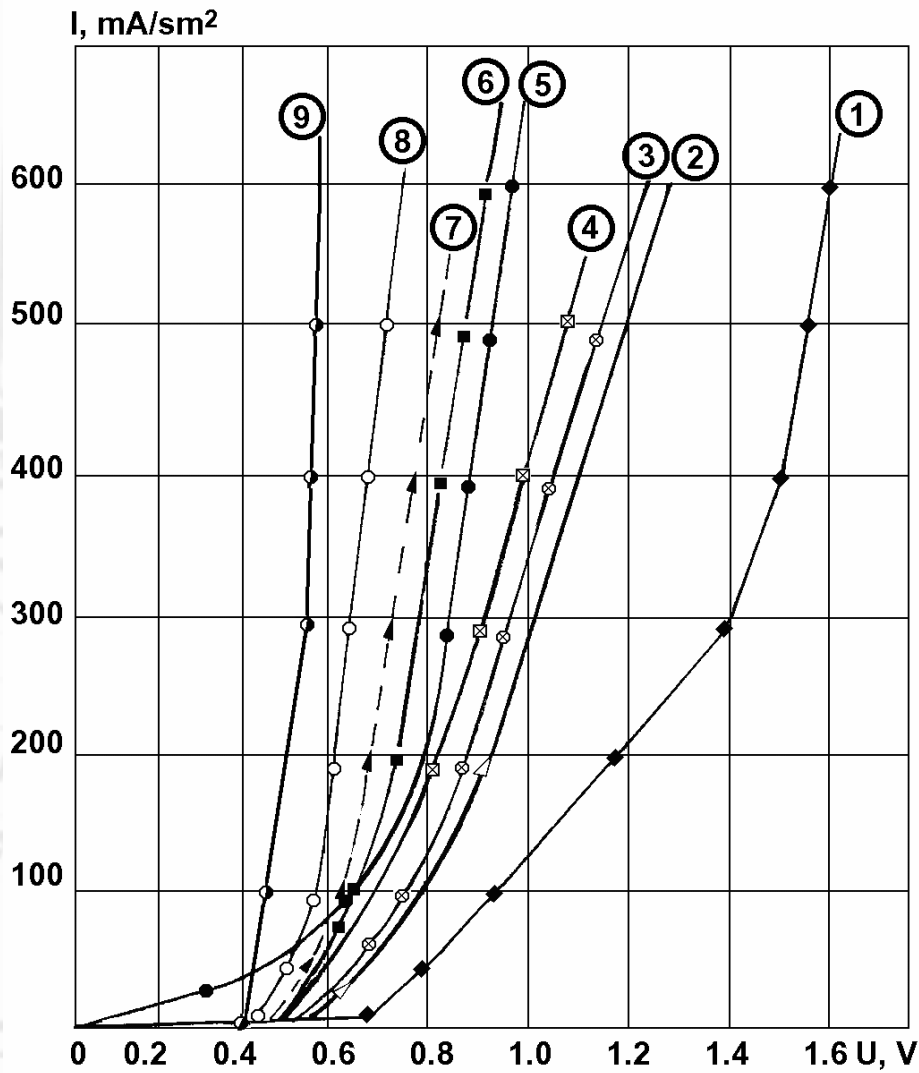

1 – stainless steel netting

2 – nickel-plated stainless netting

3 – smooth nickel foil

4 – nickel-plated nickel foil

5 – nickel-plated nickel netting

6 – composite-plated nickel netting
without cycling

7-8 – the same with cycling

9 – composite-plated nickel netting with
content of platinum about 0,5 mg/cm²
of visible electrode surface

POLARIZATION CURVES OF CATHODIC FORMATION ON STAINLESS STEEL NETTING

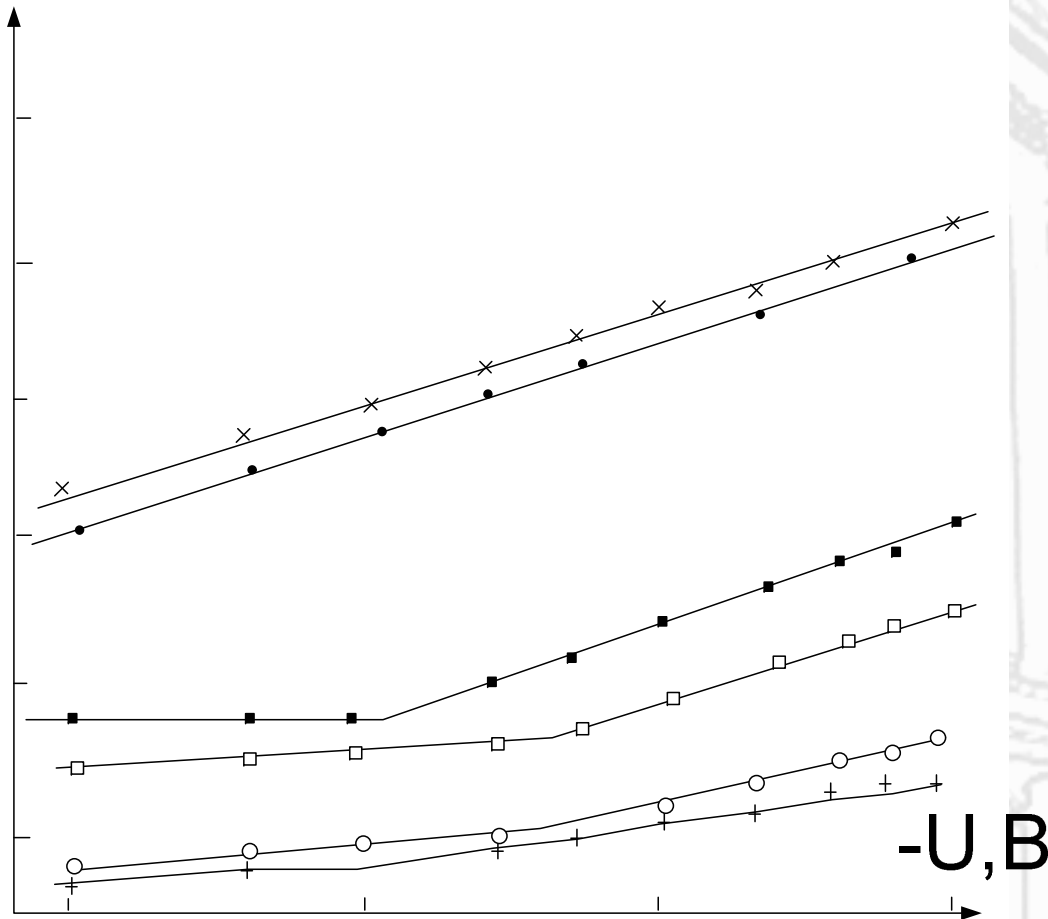

- 1 – without covering
- 2 – nickel-plated (5 mkm)
- 3 – Ni-Mo plated (7 mkm)
- 4 – Ni нанесенный на сетку
- 5 – Ni-P
- 6 – Ni-Mo-S plated (7 mkm)

IMPROVED DIAPHRAGMS AND MEMBRANES



Porous polymeric diaphragm for electrolyzer with gap

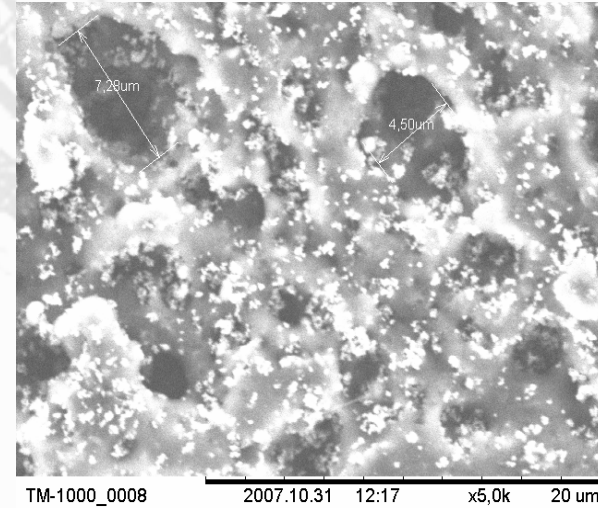

Membrane for zero-gap electrolyzer.

Application No 2006143238/04 filled 15/05/2007 “Membrane for electrochemical decomposition of water” (Inventors: Kuleshov N., Kuleshov V., Terentiev A.)

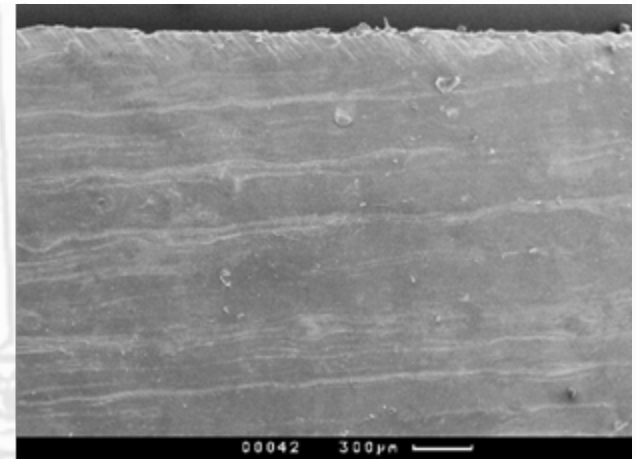

NEW ALKALINE ELECTROLYSIS CELL

High effective electrodes without precious metals content

Power consumption 4,2 kW-hour/nM3 under current density 3 kA/M2

Purity of hydrogen at battery output up to 99,7 %

Absence of asbestos diaphragm

Compactness

Possibility of hydrogen consumption regulation at wide range



ELECTROLYTIC CELLS WITH PEM

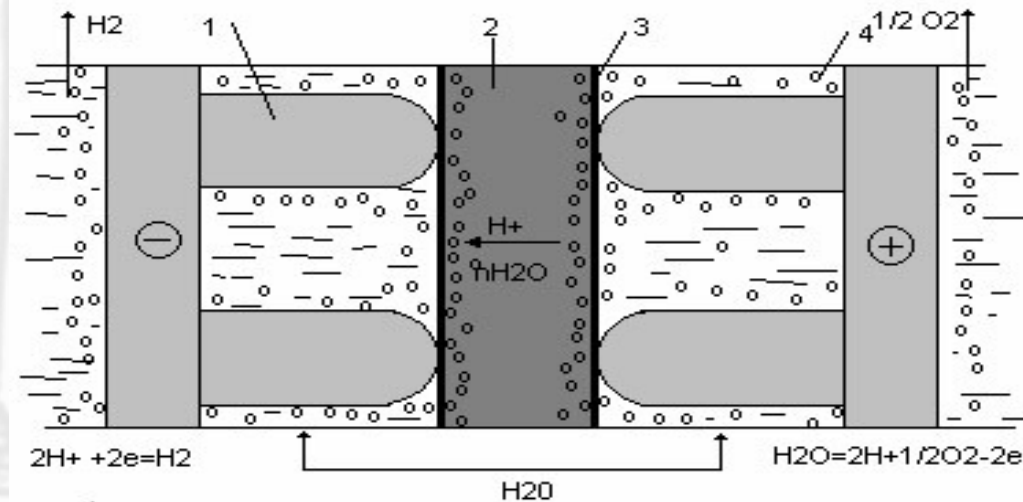

Schematic diagram of electrolytic Cell with PEM.

- 1 – current collector**
- 2 – PEM membrane**
- 3 – gas bleb**

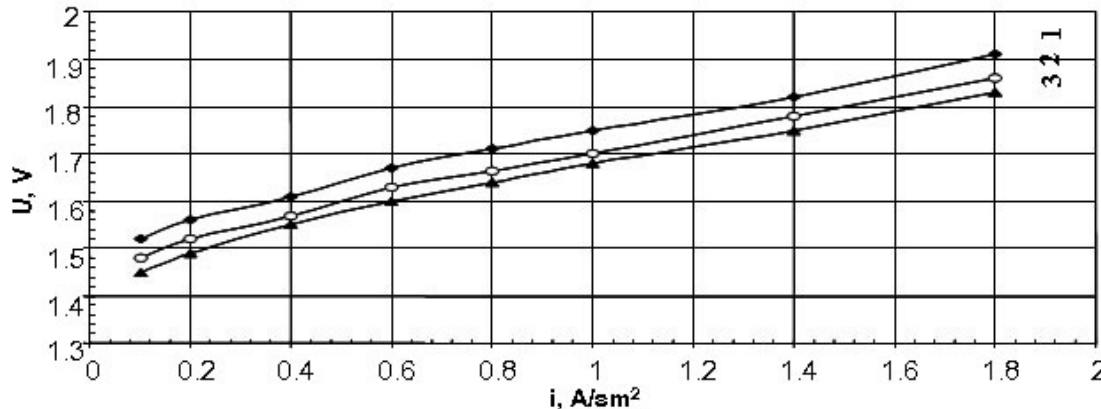

Current-voltage characteristic of electrolytic cell with 7 cm² area PEM under $t=90\text{ }^\circ\text{C}$.

Cathode catalyst: Pt/C 30 mass % - 2,0 mg/cm²

Anode catalyst: 1 – Ir, 2,5 mg/cm²; 2 – RuO₂ (30 %) - IrO₂ (32%) - SnO₂ (38%), 2,0 mg/sm²; 3 – RuO₂ (50 %) - IrO₂ (50%) – 2,0 mg/cm²

SIXTH FRAMEWORK PROGRAMME ReversPEM

Co-ordinator and Project Management
Leader: PXI
Partners: All

electrocatalysis

electrocatalysis for reversible cell using Pt family metal/oxides
Leader: MPEI

Electrocatalysts for reversible cells using non-Pt compounds
Leader: KBSU
Partners: MPEI, PXI

current collectors

Gas diffusion electrodes/current collectors for reversible cells
Leader: MPEI, KI
Partners: MPEI, KI

Surface protection (electrolyser)
Leader: KI
Partners: GKN, CETH

optimization and testing

Design optimization of reversible cells
Leader: MPEI
Partners: H2 ECO, KI

Assembling and testing the reversible cells and stack
Leader: MPEI
Partners: H2 ECO, CETH

REVERSIBLE ELECTROCHEMICAL CELL

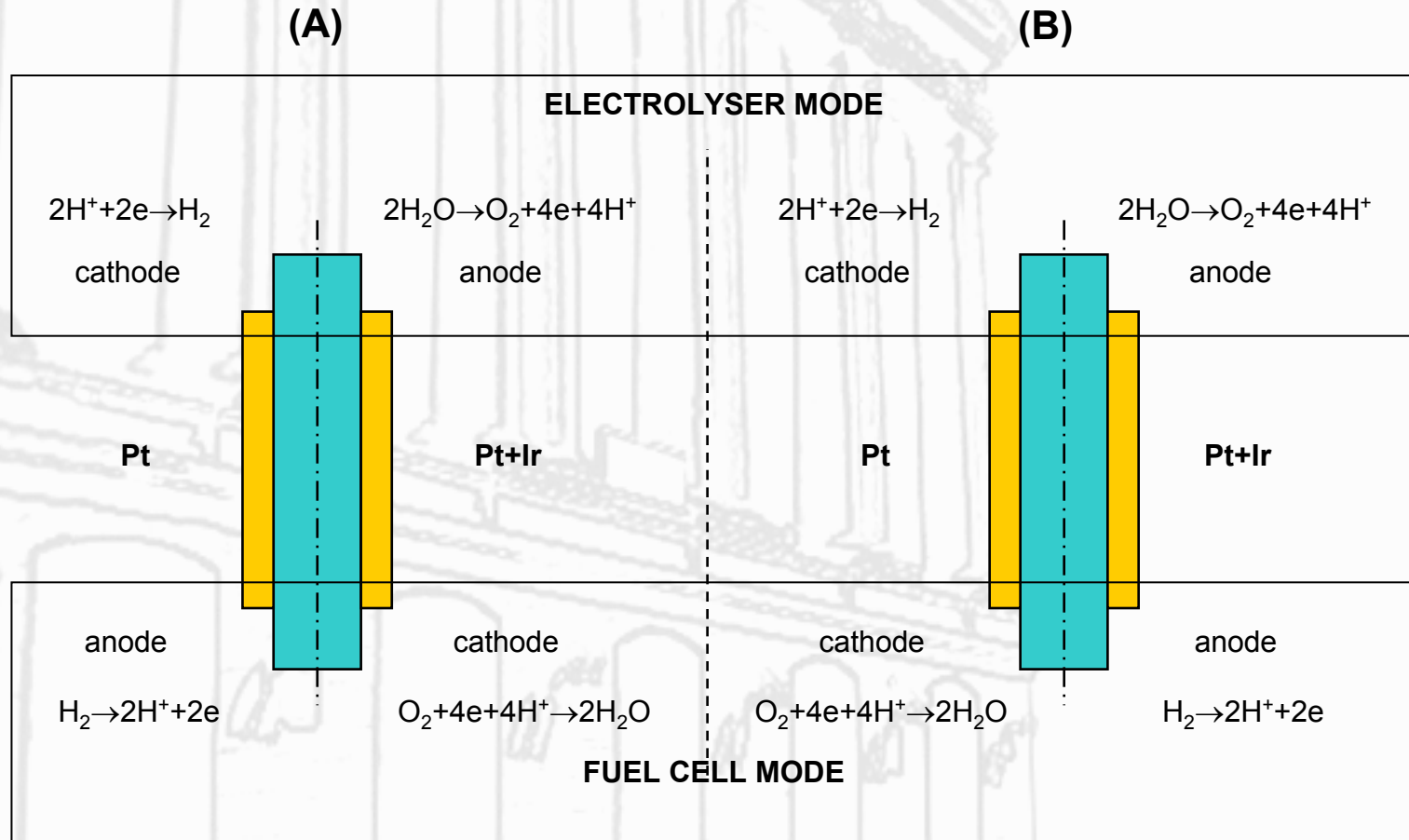

REVERSIBLE ELECTROCHEMICAL CELL

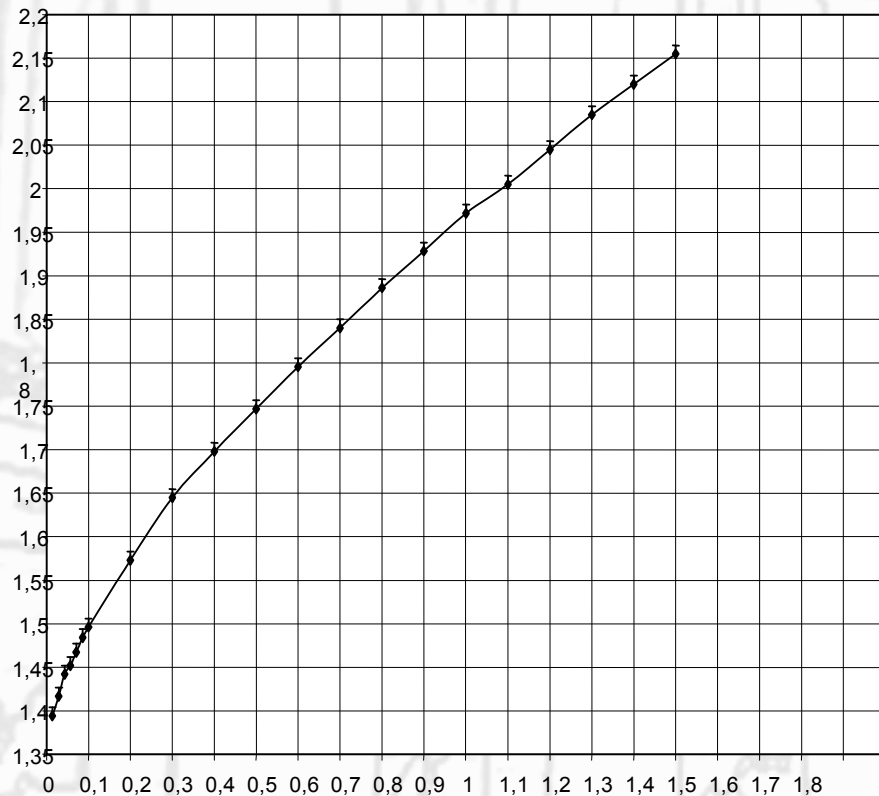

**current-voltage curve of reversible cell
in electrolyser mode
(Pt layer facing to the membrane)**

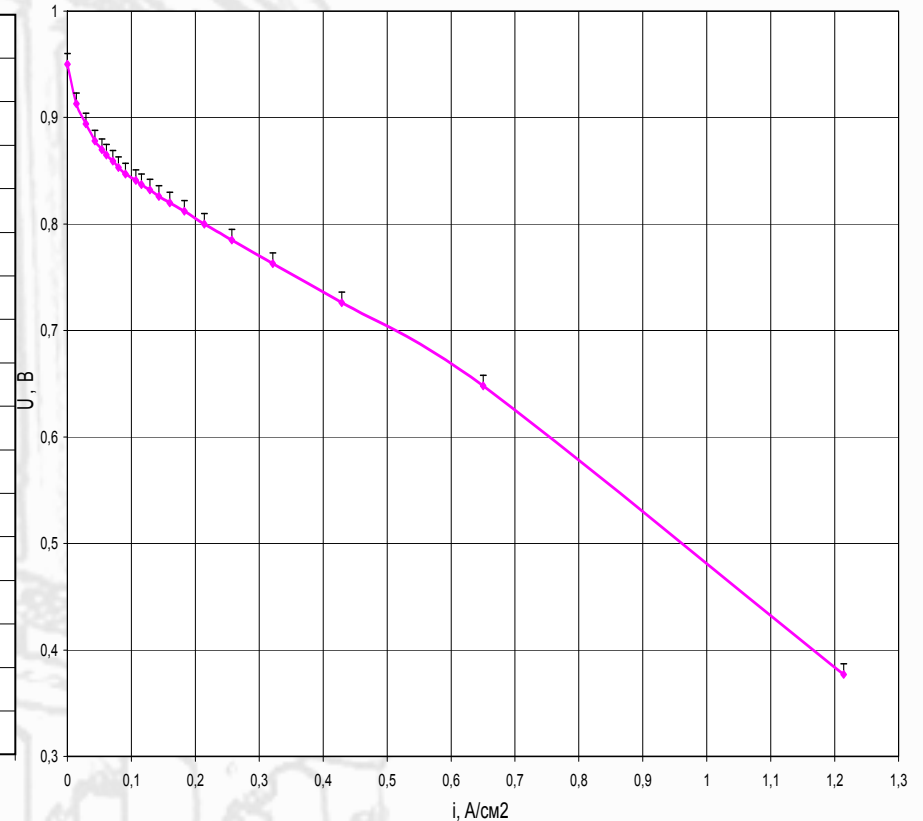

**current-voltage curve of reversible cell
in fuel cell
(Ir layer facing to the membrane)**

GAS HYDROGEN ENGINE AUTOMOBILE



САМКОТ

ИНЖЕНЕРНО-ПРОЕКТИРОВАТЕЛЬСКО-ПРОИЗВОДСТВЕННОЕ ПРЕДПРИЯТИЕ «САМКОТ»

КОНКУРЕНТОСПОСОБНОЕ ПРОИЗВОДСТВО





THANK YOU!